



# XTT 315Di

OPERATOR MANUAL

ISSUE 1

## Welcome

Thank you for choosing Parweld. This Owner's Manual is designed to help you get the most out of your Parweld products. Please take time to read the Safety Precautions. They will help you protect yourself against potential hazards in the workplace. With proper maintenance this equipment should provide years of reliable service. All our systems conform to ISO9001: 2015 and are independently audited by NQA.

The entire product range carries the CE and UKCA mark, and is constructed in accordance with European directives and the product specific standards where they apply.

## Further Information

Parweld is the UK's leading supplier of MIG, TIG and Plasma torches and consumables.

For more information about Parweld's complete range visit: [www.parweld.com](http://www.parweld.com)



# Contents

	Page
<b>1.0 Safety Precautions .....</b>	<b>4</b>
<b>2.0 Product Description .....</b>	<b>5</b>
<b>3.0 Technical Specifications .....</b>	<b>6</b>
<b>4.0 Description of Controls.....</b>	<b>6</b>
<b>5.0 Installation.....</b>	<b>7</b>
5.1 Unpacking the Machine.....	7
5.2 Location.....	7
5.3 Input and Grounding Connection .....	7
5.4 Output Polarity Connections.....	7
5.5 Liquid Cooling.....	7
<b>6.0 Operation.....</b>	<b>8</b>
6.1 Use of Controls.....	8
6.2 Changing Language .....	8
6.3 Process Selection .....	9
<b>7.0 TIG Welding Getting started .....</b>	<b>9</b>
6.1 TIG torch installation.....	9
7.2 TIG Torch Trigger type.....	9
7.3 Synergic TIG .....	9
7.4 Manual TIG explanation of controls.....	10
7.5 Tigger modes .....	12
7.5.1 2T Trigger operation .....	12
7.5.2 4T Trigger operation .....	12
<b>8.0 Manual Tig Welding How to set .....</b>	<b>13</b>
8.1 DC TIG Welding (no Pulse).....	13
8.2 AC TIG Welding (no Pulse) .....	15
8.3 AC Current Balance .....	17
8.4 Pulse TIG Welding .....	17
8.5 Advanced TIG functions .....	18
8.5.1 Q Start (DC TIG) .....	18
8.5.2 AC Wave form .....	18
8.5.2 AC Mix .....	18
8.5.4 Spot Welding.....	19
8.5.5 stitch Welding.....	20
<b>9.0 Memory .....</b>	<b>21</b>
9.1 Saving to memory .....	21
9.2 Recalling from memory .....	21
<b>10.0 MMA welding .....</b>	<b>22</b>
10.1 Advanced MMA functions .....	22
<b>11.0 Welding guide .....</b>	<b>23</b>
11.1 TIG welding .....	23
11.2 MMA welding.....	23
<b>12.0 Fault finding .....</b>	<b>24</b>
12.1 MMA problems .....	24
12.2 TIG problems .....	25
<b>13.0 Accessories .....</b>	<b>27</b>
13.1 Torch spares .....	27
13.2 Gas Equipment .....	27
13.3 TIG Torches.....	28
<b>14.0 EC Declaration of Conformity.....</b>	<b>30</b>
14.1 RoHS Compliance Declaration.....	30
14.2 WEEE Statement .....	31
14.3 Statement of Warranty.....	31

# 1.0 Safety Precautions

## **ELECTRIC SHOCK can kill.**

Touching live electrical parts can cause fatal shocks or severe burns. The electrode and work circuit is electrically live whenever the output is on. The input power circuit and machine internal circuits are also live when power is on.

Do not touch live electrical parts.

Wear dry, sound insulating gloves and body protection.

Insulate yourself from work and ground using dry insulating mats or covers big enough to prevent any physical contact with the work ground.

Additional safety precautions are required when any of the following electrically hazardous conditions are present: in damp locations or while wearing wet clothing; on metal structures such as floors, gratings, or scaffolds; when in cramped positions such as sitting, kneeling, or lying; or when there is a high risk of unavoidable or accidental contact with the work piece or ground.

Disconnect input power before installing or servicing this equipment. Lockout/tag out input power according to Safety Standards.

Properly install and ground this equipment according to national and local standards.

Always verify the supply ground - check and ensure that input power cable ground wire is properly connected to ground terminal in the receptacle outlet.

When making input connections, attach proper grounding conductor first - double-check connections.

Frequently inspect input power cable for damage or bare wiring - replace cable immediately if damaged - bare wiring can kill.

Turn off all equipment when not in use.

Do not use worn, damaged, under sized, or poorly spliced cables.

Do not drape cables over your body.

If earth grounding of the work piece is required, ground it directly with a separate cable.

Do not touch electrode if you are in contact with the work, ground, or another electrode from a different machine.

Use only well-maintained equipment. Repair or replace damaged parts at once. Maintain unit according to manual.

Wear a safety harness if working above floor level.

Keep all panels and covers securely in place.

Clamp work cable with good metal-to-metal contact to work piece or worktable as near the weld as practical.

Insulate work clamp when not connected to work piece to prevent contact with any metal object.

Welding produces fumes and gases. Breathing these fumes and gases can be hazardous to your health.

## **FUMES AND GASES can be hazardous.**

Keep your head out of the fumes. Do not breathe the fumes.

If inside, ventilate the area and/or use local forced ventilation at the arc to remove welding fumes and gases.

If ventilation is poor, wear an approved respirator.

Read and understand the Material Safety Data Sheets (MSDS's) and the manufacturer's instructions for metals, consumable, coatings, cleaners, and de-greasers.

Work in a confined space only if it is well ventilated, or while wearing an air-supplied respirator. Always have a trained watch person nearby. Welding fumes and gases can displace air and lower the oxygen level causing injury or death. Be sure the breathing air is safe.

Do not weld in locations near de-greasing, cleaning, or spraying operations. The heat and rays of the arc can react with vapours to form highly toxic and irritating gases.

Do not weld on coated metals, such as galvanized, lead, or cadmium plated steel, unless the coating is removed from the weld area, the area is well ventilated, and while wearing an air-supplied respirator. The coatings and any metals containing these elements can give off toxic fumes if welded.

## **ARC RAYS can burn eyes and skin.**

Arc rays from the welding process produce intense, visible and invisible (ultraviolet and infrared) rays that can burn eyes and skin. Sparks fly off from the weld.

Wear an approved welding helmet fitted with a proper shade of filter lens to protect your face and eyes when welding or watching

Wear approved safety glasses with side shields under your helmet.

Use protective screens or barriers to protect others from flash, glare and sparks; warn others not to watch the arc.

Wear protective clothing made from durable, flame resistant material (leather, heavy cotton, or wool) and foot protection. Welding on closed containers, such as tanks, drums, or pipes, can cause them to blow up. Sparks can fly off from the welding arc. The flying sparks, hot work piece, and hot equipment can cause fires and burns. Accidental contact of electrode to metal objects can cause sparks, explosion, overheating, or fire. Check and be sure the area is safe before doing any welding.

## **WELDING can cause fire or explosion.**

Remove all flammables within 10m of the welding arc. If this is not possible, tightly cover them with approved covers.

Do not weld where flying sparks can strike flammable material.

Protect yourself and others from flying sparks and hot metal.

Be alert that welding sparks and hot materials from welding can easily go through small cracks and openings to adjacent areas.

Watch for fire, and keep a fire extinguisher nearby. Be aware that welding on a ceiling, floor, bulkhead, or partition can cause fire on the hidden side.

Do not weld on closed containers such as tanks, drums, or pipes, unless they are properly prepared according to local regulations

Connect work cable to the work as close to the welding area as practical to prevent welding current from travelling along, possibly unknown paths and causing electric shock, sparks, and fire hazards.

Wear oil-free protective garments such as leather gloves, heavy shirt, cuffless trousers, high shoes, and a cap. Remove any combustibles, such as a butane lighter or matches, from your person before doing any welding.

**FLYING METAL can injure eyes.**

Welding, chipping, wire brushing, and grinding cause sparks and flying metal. As welds cool they can throw off slag. Wear approved safety glasses with side shields even under your welding helmet.

**BUILDUP OF GAS can injure or kill.**

Shut off shielding gas supply when not in use. Always ventilate confined spaces or use approved air-supplied respirator.

**HOT PARTS can cause severe burns.**

Do not touch hot parts with bare hands.

Allow cooling period before working on gun or torch.

To handle hot parts, use proper tools and/or wear heavy, insulated welding gloves and clothing to prevent burns.

**ELECTRICAL AND MAGNETIC FIELDS**

Can affect pacemakers Pacemaker wearers keep away. Wearers should consult their doctor before going near arc welding, gouging, or spot welding operations.

Welders should use the following procedures to minimize exposure to Electrical and Magnetic Fields

Route the electrode and work cables together. Secure them with tape when possible.

Never coil the torch or work cable around your body.

Do not place your body between the torch and work cables. Route cables together on the same side of your body.

Connect the work cable to the work piece as close as possible to the area being welded.

Keep the welding power source and cables as far away from your body as possible.

**NOISE can damage hearing.**

Noise from some processes or equipment can damage hearing.

Wear approved ear protection if noise level is high.

Shielding gas cylinders contain gas under high pressure.

**CYLINDERS can explode if damaged.**

Protect compressed gas cylinders from excessive heat, mechanical shocks, physical damage, slag, open flames, sparks, and arcs. Install cylinders in an upright position by securing to a stationary support or cylinder rack to prevent falling or tipping. Keep cylinders away from any welding or other electrical circuits. Never drape a welding torch over a gas cylinder. Never allow a welding electrode to touch any cylinder. Never weld on a pressurized cylinder - explosion will result. Use only correct shielding gas cylinders, regulators, hoses, and fittings designed for the specific application; maintain them and associated parts in good condition.

Turn face away from valve outlet when opening cylinder valve.

Use the right equipment, correct procedures, and sufficient number of persons to lift and move cylinders.

Read and follow instructions on compressed gas cylinders, associated equipment, and Compressed Gas Association (CGA) recommendations.

## 2.0 Product Description

The XTT 315Di is a multi-mode TIG welding machine using inverter technology. A micro controller allows the machine to be quickly and easily configured for TIG welding in DC or multiple AC modes . Within each welding mode there are features and functions which improve the welding performance and ease of use as detailed below.

TIG processes can be rapidly configured through the use of synergic programs where the base settings are already programmed into the machine and the user only needs to provide information on the material type and thickness.

TIG welding controls:- Synergic or manual parameter setting for Pre Gas, Upslope, Welding current, pulse parameters, AC frequency, downslope and post gas time.

MMA Controls:- Manual setting of welding Power. Adjustable Hotstart which assists electrode striking by boosting the start current.

Arc Force increases the current when the arc gets too short, to prevent the electrode sticking to the job; the level of arc force is user adjustable. You may wish to increase arc force so you can dig the electrode into the work piece for improved penetration; the level of arc force selected will depend upon the type of electrode and joint configuration.

## 3.0 Technical Specifications

XTT315 Di		PARWELD LTD, BENDLEY BUSINESS PARK, LONG BANK BENDLEY, WORCESTERSHIRE, DY12 2TZ, ENGLAND.				
	ISO/IEC 60974-1 RoHS Compliant		CE UK CA			
5 No.						
WELDING OUTPUT						
	~25-250Hz	X	AC		DC	
			10A/10.4V-315A/22.6V	60%	100%	5A/10.2V-315A/22.6V
	$U_s = 56V$	$I_2$	315A	220A	315A	220A
		$U_2$	22.6V	18.8V	22.6V	18.8V
	~25-250Hz	X	AC		DC	
			10A/10.4V-270A/30.8V	70%	100%	5A/10.2V-270A/30.8V
	$U_s = 30V$ (56V)	$I_2$	270A	210A	270A	210A
		$U_2$	30.8V	28.4V	30.8V	28.4V
ENERGY INPUT						
	$U_i = 400V$ 3-50/60Hz	IP235	F	TIG	$I_{max} = 15.1A$	$I_{ref} = 11.7A$
				MMA	$I_{max} = 16.9A$	$I_{ref} = 14.1A$
				$\approx 16A$	GENERATOR SIZE: 17 KVA	

### Control Plug wiring

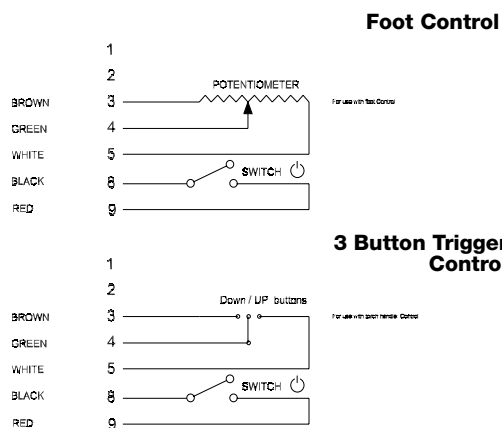

## 4.0 Description of Controls

- 1) ON OFF Switch** For switching on or off the mains supply to the machine. Note the output of the machine is permanently on in MMA mode unless the on/off switch is in the off position.
- 2) Mains Input Cable**
- 3) Shielding Gas Input Connection**
- 4) Gas Output Connection** This is a 3/8 BSP connection for the gas output connection to the welding torch (TIG welding)
- 5) Negative Connection** This is used to connect the TIG torch or the earth lead in MMA welding.
- 6) Positive Connection** This is used to connect the electrode holder in MMA or the earth lead in TIG welding.

**7) Control Socket** This is used to control the machine remotely using a trigger or amperage control.

**8) Multifunction Control Knob** This knob is used to navigate and select menus on the LCD display.

**9) Advanced Button** Press this button to access the advanced menus for each process.

**10) Memory Button** If you press this button in any welding screen it saves the current set of welding parameters to memory.

**11) Digital Display**



## 5.0 Installation

Read entire installation section before starting installation.

### SAFETY PRECAUTIONS

- **ELECTRIC SHOCK can kill.**
- **Only qualified personnel should perform this installation.**
- **Only personnel that have read and understood the Operating Manual should install and operate this equipment.**
- **Machine must be grounded per any national, local or other applicable electrical regulations.**
- **The power switch is to be in the OFF position when installing work cable and electrode cable and when connecting other equipment.**

### 5.1 Unpacking the Machine

Carefully remove the machine from the packaging, we recommend you retain the packaging until the machine has been fully installed and tested in case it has been damaged in transit and has to be returned to the re-seller.

### 5.2 Location

Be sure to locate the welder according to the following guidelines:

In areas, free from moisture and dust.

Ambient temperature between 0-40°C.

In areas, free from oil, steam and corrosive gases.

In areas, not subjected to abnormal vibration or shock.

In areas not exposed to direct sunlight or rain.

Place at a distance of 12" (300 mm) or more from walls or similar that could restrict natural airflow for cooling.

### 5.3 Input and grounding connection

#### WARNING

**Before starting the installation, check that your power supply is adequate for the voltage, amperage, phase, and frequency specified on the Machine nameplate.**

Operate the welding power source from a three-phase 50/60 Hz, AC power supply. The input voltage must match one of the electrical input voltages shown on the input data label on the unit nameplate. The XTT-315P ACDC machine should only be used on 400V supply. Refer to the specifications table for voltage tolerances.

Have a qualified electrician connect the input plug. For long runs over 30m, larger copper wires should be used. The green/yellow wire in the input cable connects to the frame of the machine. This ensures proper grounding of the machine when the machine plug is inserted into the receptacle.

### 5.4 Output Polarity Connections

Electrode polarity

MMA electrodes are generally connected to the '+' terminal and the work return lead to the '-' terminal

But if in doubt consult the electrode manufacturer's literature.

IF TIG welding the torch should always be connected to the '-' terminal.

### 5.5 Liquid Cooling (optional water cooler)

The Liquid Cooled system on your Welding Machine

It is critical to correctly maintain the Cooling unit if fitted to your system. If your machine does not have a liquid cooling system for the torch this can be retro fitted to most models should you wish to enhance your package in the future.

The correct coolant (Parweld Ultracool, Stock Code XTSUC) must be used in the unit to the required level indicated on the unit. In addition to cooling the torch, the Coolant lubricates the workings of the pump. It contains antibacterial agents and Anti-Freeze to stop the liquid freezing in low temperatures.

It is also important to regularly inspect all connecting hoses between the cooling unit & the machine & the machine to the welding torch. This will identify any potential leaks that will affect the coolant level & potentially damaging the cooling unit, welding machine and torch.

Should damage be caused by a failure to maintain the correct level of the correct Coolant within the system it will void any warranty claims.

## 6.0 Operation

### 6.1 Use of Controls

**Multifunction Control Knob.**

Rotate and Select

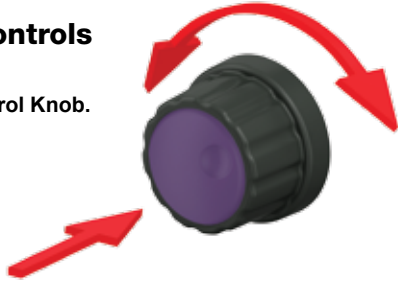

Rotate left or right to highlight an option on the screen.  
Press to select  
Press and hold to step back in menu tree

### 6.2 Language of Operation



### 6.3 Process Selection

**TIG Synergic TIG Welding Setup**

Allows rapid setting of key parameters



HF Start TIG Welding Setup (Manual)



Lift Start TIG Welding Setup (Manual)



MMA Welding Setup (Manual)



# 7.0 TIG Welding Setting the Machine

## 7.1 TIG Torch Installation

Connect the torch as show below, ensure the torch power cable is connected to the Negative polarity connection, the gas nut should be connected the threaded gas outlet and the Trigger plug located into the trigger socket. this diagram can be viewed in the help menu under setup

Pure Argon gas should be used and the is connected to the rear of the machine using the hose supplied.

Note:- shorting or dipping the electrode into the weld pool for more than 1 second will cause the machine to reduce the welding power to zero in order to protect the tungsten and minimise contamination



## 7.2 TIG Torch Trigger type

Check the correct trigger type is configured in the Help menu

Select torch



Select the correct trigger type,

For 1 or 3 button trigger select the left hand option.

For wheel type current control select the middle option.

For Foot control select the right hand option.



## 7.3 Synergic TIG Welding SetUp

Follow the screen prompts to complete the Synergic machine set up. Synergic Setting allows rapid setting of the machine based on material type and thickness, with HF starting.

Example:



Set the process mode to 2T or 4T if you prefer a latching trigger action. (Note in 4T position you must press and release to start the process and press and release again to stop the process)



Select the material to be welded



Select the Tungsten diameter



Select the Material thickness

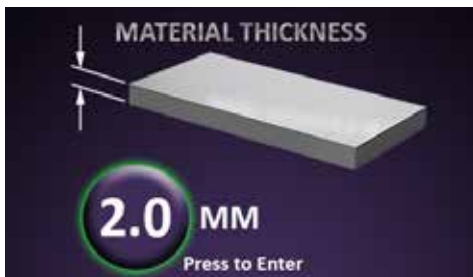

You are now ready to weld. If you wish to change to advanced parameters, press the Advanced button



#### 7.4 Manual TIG Welding Explanation of controls

Follow the screen prompts to complete the machine set up. Manual Setting allows access to all the TIG parameters. Following is an example of menu navigating for manual setup.



The welding parameters setting screen will now load

Rotate the selector knob to move the red dot up and down the graph. Press and release the selector knob to make the red dot flash, you can now adjust the selected parameter. Press and release the selector knob again to set and move on.

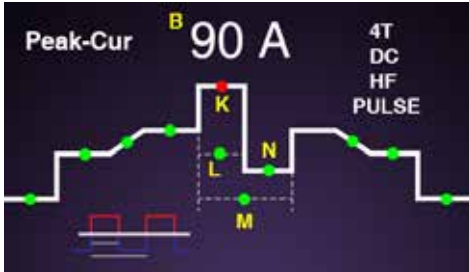

Note not all parameters will be available dependent upon the welding mode selected (AC or DC, 2T or 4T etc)

Pre-gas adjustable from 0.1 to 10.0 seconds. The value is displayed in the display



Ignition current. (B) This is the power used to start the arc, it is present only during the starting of the arc. Larger tungsten perform better with a higher start current. The minimum value is 40A.

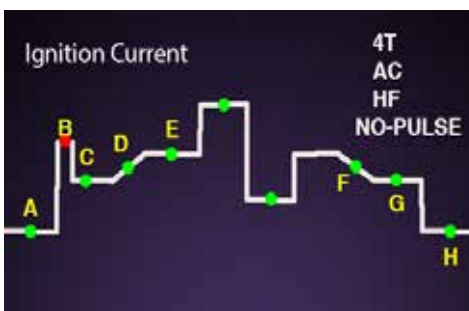

Initial current (C) This can be adjusted from 5 to 300A (10-300A in AC) The value is displayed on the display. Setting the initial current lower than the main welding current gives a slow start to the weld. Setting the value higher than the main welding means you can pre-heat the job quickly before welding.

Note this function only operates in 4T switch mode.



Slope up time (D) This can be adjusted from 0 to 10s. The value is displayed on the display This is the time taken for the welding current to adjust to the main current.

Note this function only operates in 4T switch mode.

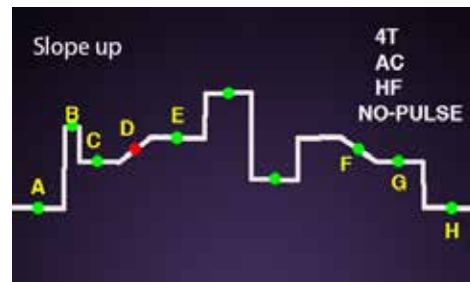

Main welding current, This can be adjusted from 5 to 300A (10-300A in AC). The value is displayed on the display. Refer to the TIG welding guide for a recommended welding current.



Slope down time This can be adjusted from 0 to 10s. The value is displayed on the display 1s is a good initial setting.

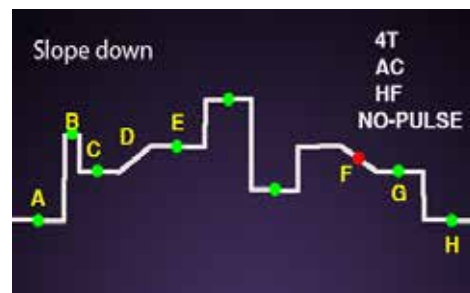

**Final current.** This can be adjusted from 5 to 300A. (10-300A in AC)  
 Final current allows for crater filling or welding to an open edge. **Note**  
 this function only operates in 4T switch mode.

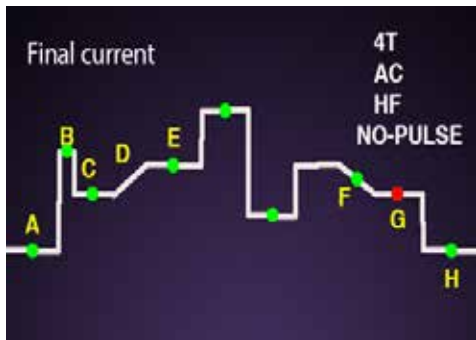

**Post Gas time** This can be adjusted from 0.1 to 10s. The value is displayed on the display Post gas ensures weld protection until the weld has cooled.

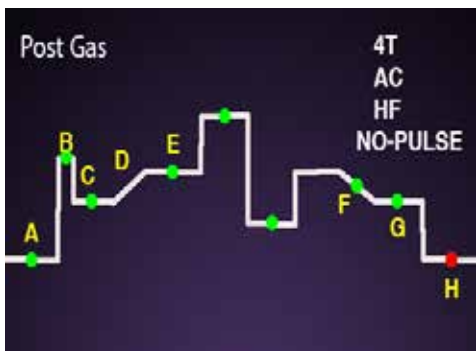

## 7.5 Standard Trigger modes

### 7.5.1 2T mode

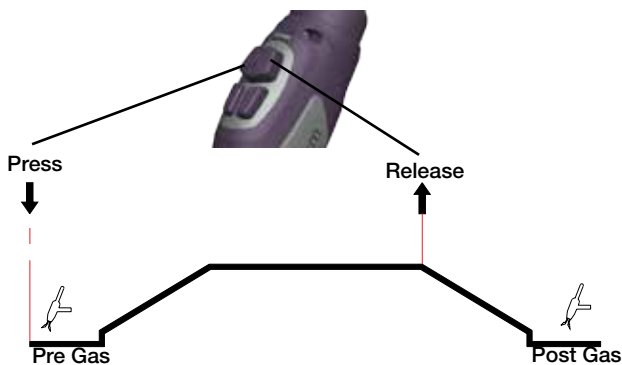

### 7.5.2 4T mode

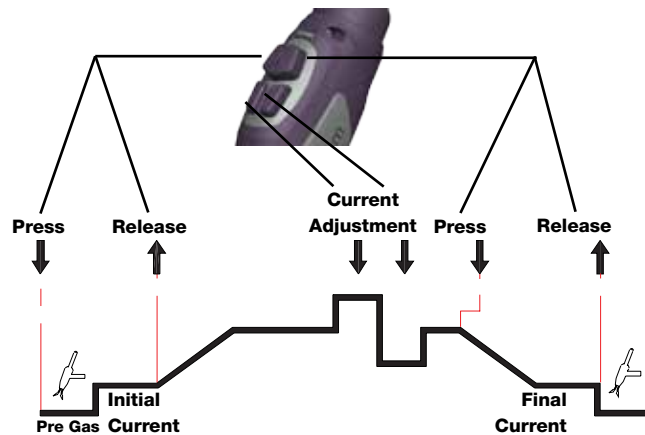

### Step Current, 4T mode

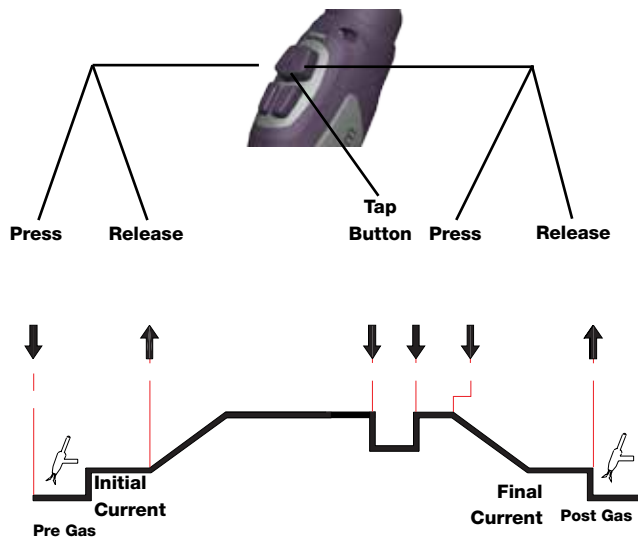

# 8.0 Manual setup Typical configurations

## 8.1 DC TIG welding (No Pulse)



Select HF TIG



Select DC output

Set the process mode to 2T or 4T if you prefer a latching trigger action. (Note in 4T position you must press and release to start the process and press and



release again to stop the process)



Select No Pulse

Using the control knob move the red dot to the gas pre-flow position (A) and press the knob so that the dot is flashing.

Adjust the parameter value by rotating the Control knob This can be adjusted from 0.0 to 1.0 seconds. 0.5 seconds is normally adequate. Press the control knob

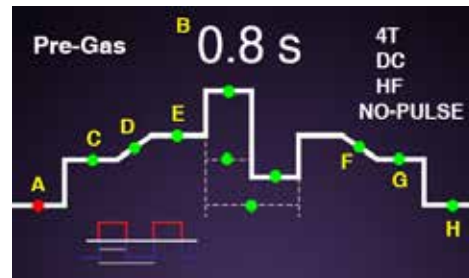

to finish adjustment.

**Ignition current.** (B) This is the power used to start the arc, it is present only during the starting of the arc. Larger tungsten perform better with a higher start current The minimum value is 40A. We Recommend 40A for electrodes up to 3.2mm and 60A for larger



sizes

Rotate the control knob to move the LED to the initial current (C). **Note this function only operates in 4T switch mode**

**Initial current (C)** This can be adjusted from 5 to 300A (10-300A in AC) The value is displayed on the display. Set the initial current so it is 50% of the welding current you are intending to use **Note this**

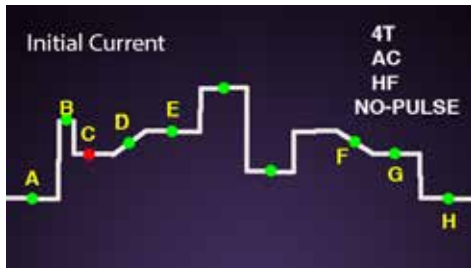

function only operates in 4T switch mode.



Slope up time (C) 2s is a good initial setting.

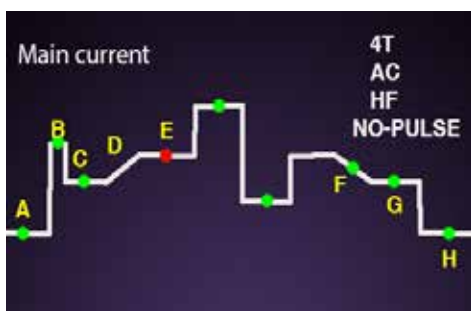

Main welding current (D) Refer to the TIG welding guide for a recommended welding current.

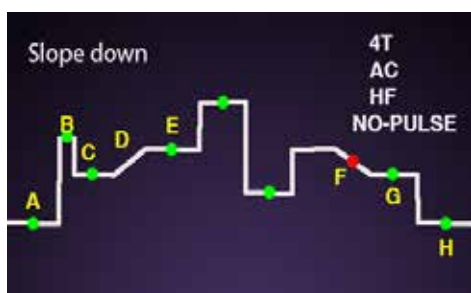

slope down time (K) This can be adjusted from 0 to **Note this function only operates in 4T switch mode**

2s is a good initial setting. It should be activated by pressing the trigger close to the end of the weld so you can continue to add filler metal but at a slower rate so avoiding a crater at the end of the weld or melting the edge of the plate

Rotate the control knob to move the LED to the final current (G) This can be adjusted from 5 to 100% of the main welding current. 50%

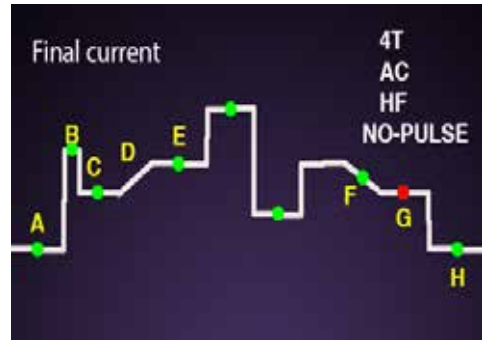

is a good initial setting. The final current should allow the weld to cool and you to be able to finish off any filler metal addition but at a slower rate **Note this function only operates in 4T switch mode**

Rotate the control knob to move the LED to the Post Gas time (H).

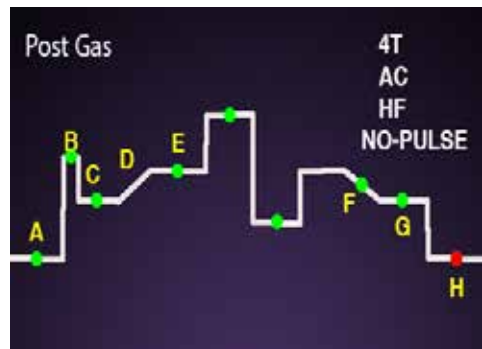

This can be adjusted from 0.1 to 10s. 3s is a good initial setting. If the weld material is still Red or is becoming oxidized increase the post gas time and ensure you do not move the torch away from the job until the post gas has stopped

You are now ready to weld. These settings are a guide and you should adjust to suit the job you are welding. If you are unfamiliar with the machine try to adjust only one parameter at a time so you become familiar with its effect.

## 8.2 AC TIG welding (No Pulse)

Note:- shorting or dipping the electrode into the weld pool for more than 1 second will cause the machine to reduce the welding power to zero in order to protect the tungsten and minimise contamination.

Select HF TIG.



Select No Pulse



Using the control knob move the red dot to the gas pre-flow position (A) and press the knob so that the dot is flashing.

Adjust the parameter value by rotating the Control knob This can be adjusted from 0.0 to 1.0 seconds. 0.5 seconds is normally adequate. Press the control knob to finish adjustment.

Select AC

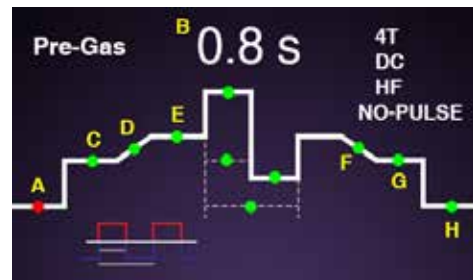

**Ignition current.** (B) This is the power used to start the arc, it is present only during the starting of the arc. Larger tungsten perform better with a higher start current. The minimum value is 40A. We Recommend 40A for electrodes up to 3.2mm and 60A for larger sizes

Set the control mode to 2T or 4T if you prefer a latching trigger action. (Note in 4T position you must press and release to start the process and press and release again to stop the process)

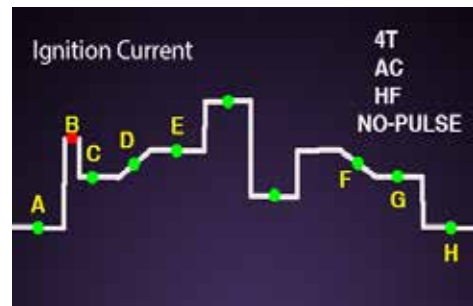

**Initial current (C)** This can be adjusted from 10-300A T. Set the initial current so it is approx 150% of the welding current you are intending to use This will give a rapid preheating of the Aluminium plate. **Note this function only operates in 4T switch mode.**



**Slope up time (C)** 2s is a good initial setting.

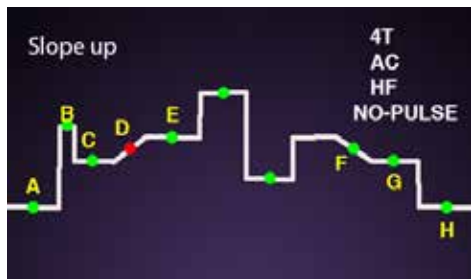

**Main welding current (D)** Refer to the TIG welding guide for a recommended welding current.

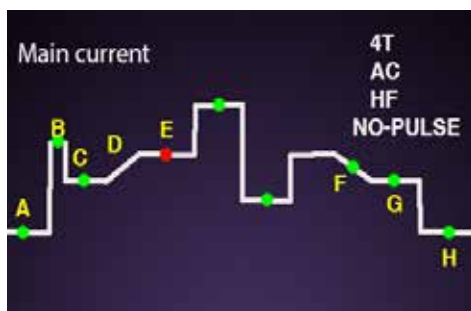

**slope down time (K)** This can be adjusted from 0 to **Note this function only operates in 4T switch mode**

2s is a good initial setting. It should be activated by pressing the trigger close to the end of the weld so you can continue to add filler metal but at a slower rate so avoiding a crater at the end of the weld or melting the edge of the plate



Rotate the control knob to move the LED to the final current (G) This can be adjusted from 5 to 100% of the main welding current. 50% is a good initial setting. The final current should allow the weld to cool and you to be able to finish off any filler metal addition but at a slower rate **Note this function only operates in 4T switch mode**

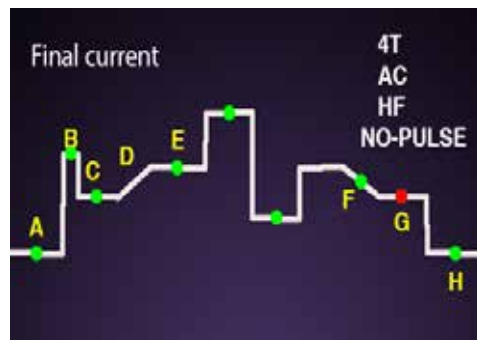

Rotate the control knob to move the LED to the Post Gas time (H). This can be adjusted from 0.1 to 10s. 3s is a good initial setting. If the weld material is still Red or is becoming oxidized increase the post gas time and ensure you do not move the torch away from the job until the post gas has stopped

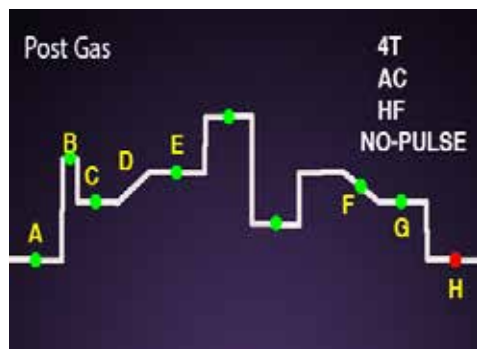

Rotate the control knob to move the LED to the AC frequency 60hz is a good initial setting. Increasing the frequency has the effect of stiffening and focussing the arc making it good for welding close to threads or for crater filling. It also increases the heat input and so the speed of welding

Note the maximum frequency available depends upon the welding amperage selected.

Less than 124A	25 to 250Hz
124-155A	Max 210Hz
155-186A	Max 160Hz
186-217A	Max 110Hz
217A and above	Max 75Hz



Rotate the control knob to move the LED to the AC Cleaning balance (J) This can be adjusted from 15 to 50%. 15% is a good initial setting. Increasing the percentage has the effect of increasing the time the arc spends in the electrode positive state which gives a greater cleaning effect on the material but will reduce weld speed. For good clean material you should be able to keep the cleaning percentage set at 15 to 20%

### 8.3 AC Current balance.

The traditional balance control maintains an equal current balance between electrode Positive (cleaning) and electrode negative (heating). (Refer above) Current Balance allows you to increase the current level on the Negative part of the cycle The current level on the Negative part of the cycle can be set between 0 and +30% at +30% it will be 30% greater than the main current setting. The effect of this function is to increase the heat input into the work piece without increasing the heat spread and so improving penetration and welding speed, Without over heating the tungsten.

You are now ready to weld. The above settings are a guide and you should adjust to suit the job you are welding. If you are unfamiliar with the machine try to adjust only one parameter at a time so you become familiar with its effect.

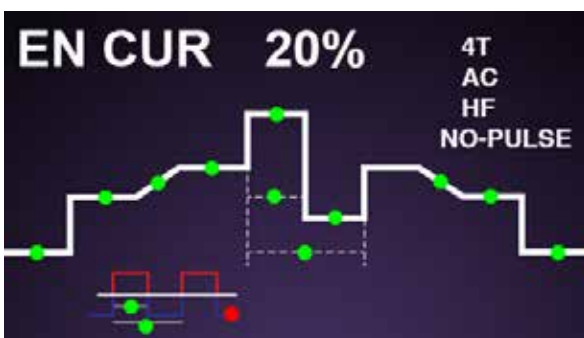

### 8.4 TIG welding (With Pulse)

It is possible to use the pulse function with both AC and DC TIG welding. Power Pulsing can give significant advantages on thinner material to control heat and penetration.

1) Follow the setup as previously described for AC or DC TIG welding. At the Pulse Selection menu select Pulse.



Press the control knob to move the LED to the Peak current (K) This can be adjusted from 5 to 300A (10-300A for AC welding) dependant on the welding amperage. The value is displayed on the digital display (B). Peak current is the maximum amperage that will be output.



Rotate the control knob to move the LED to the Peak duration (L) This can be adjusted from 5 to 100% Peak duration is the percentage of time the peak current is on relative to the background current. 30% is a good starting point.

Rotate the control knob to move the LED to the Background current (N) This can be adjusted from 5 to 300A (10-300A for AC welding). Background current is the minimum amperage that will be output. It cannot be higher than the peak current and generally will be set withing 50 to 70% of the peak current.

Rotate the control knob to move the LED to the Pulse Frequency (M) This can be adjusted from 0.5 to 200Hz. The value is displayed on the digital display (B). Pulse Frequency is the number of pulses per second generally a range of 50 to 150 hz will be used with 100Hz being a good base setting.

30-40Hz will help agitate the weld puddle and allow you to weld at a lower amperage than without pulse.

50-150Hz really stiffen the arc and let you pinpoint the arc more than without pulse.

0.5-10Hz reduces heat input the most.

The selected amperage and the consistency of travel speed can negate some of the effects of Power pulsing.

## 8.5 TIG Advanced functions

Advanced functions are available when the advanced manu is selected on the front panel.

The options in the Advanced menu will vary dependant upon if AC or DC welding is selected .Unavailable options will be greyed out

### 8.5.1 Q Start.

Used to give a good start for low current applications. Ideal for thin plate so that you can have a reliable starting arc,without burning through the plate. It works during the arc ignition mode for DC welding only.

Q Time is the time setting for the duration of the start mode.

With QStart on, returning to the welding screen you can set the level of the ignition current (Q start) 20A or above. The Arc ignition will be pulsed to assist starting without damaging the tungsten tip.

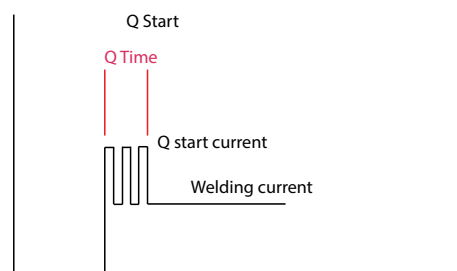
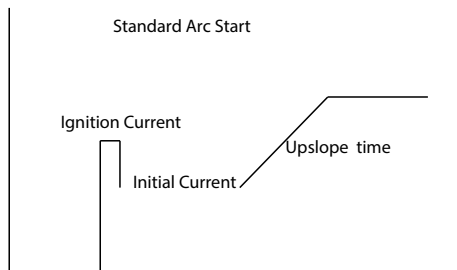

### 8.5.2 AC Wave form,

Available if AC TIG is selected

**Off**- Defaults to standard Square wave. Gives a stable arc and maximises the time in heating and cleaning modes. The arc develops a buzzing noise due to the rapid switching from positive to negative

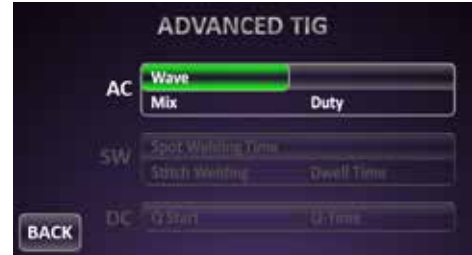

**On** Switches to wave form selected in the Right window



Square wave. Gives a stable arc and maximises the time in heating and cleaning modes. The arc develops a buzzing noise due to the rapid switching from positive to negative



**Soft square**, gives a slightly softer arc than square wave with slightly more fluidity in the weld pool



**Triangle Wave**, Low heat input wave is ideal for thin section materials using a higher AC frequency,



**Sine Wave**, Gives a soft smooth arc with reduced noise levels. Heat input is between square wave and Triangle wave with a slower welding speed.



### 8.5.3 AC MIX

This combines AC welding with DC current to increase welding speed and controls the arc spread. the duration setting sets the percentage of time spent in AC mode and the remainder is in DC. The time period for this is dependant upon the AC frequency.



### 8.5.4 Advanced switch mode Spot welding

**Spot welding** the spot welding function needs to be switched on in the trigger menu for the functions to be active.



Spot welding shows as ON and can only be disabled in the main menu.

SW Time is the duration of the welding time and can be selected and adjusted so the spot weld is of the required size.



In operation press and hold the trigger the arc will start and extinguish when the timer has elapsed. Release the trigger and press and hold again to start another spot weld.

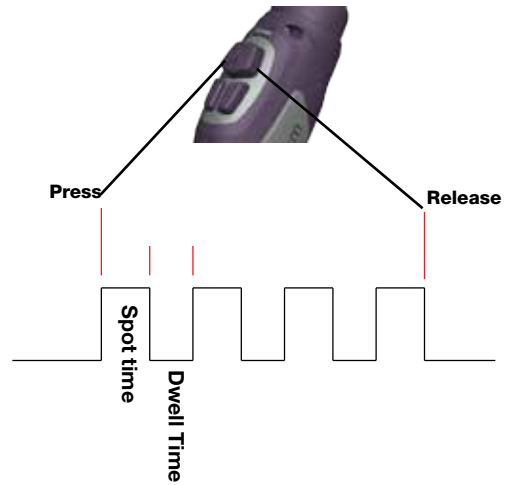
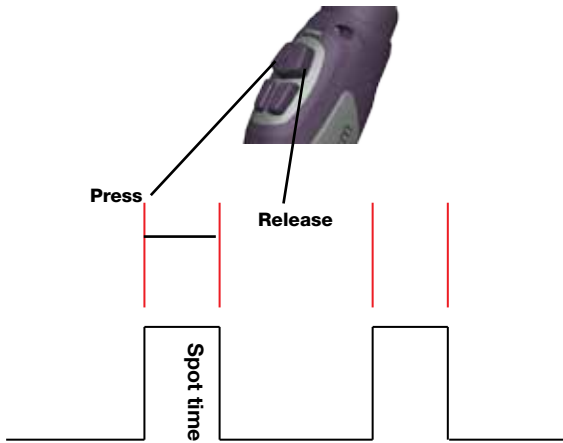

### 8.5.4 Advanced switch mode Stitch welding

**Stitch welding**, available as a secondary function to spot welding. When enabled the dwell time can be adjusted and it works to automate the process of making repeated spot welds. Press and hold the trigger down, the arc will start and go out once the spot weld time has elapsed. The dwell time will start and the arc will restart once the dwell time has elapsed. In this way multiple spot welds can be created without releasing the trigger, simply moving the torch position during the dwell time. Releasing the torch trigger will stop this process.



# 9.0 Memory

## 9.1 Saving to memory

In any welding screen apart from TIG SYN, press the memory button. If in TIG SYN mode, press the Advanced menu button first, then the memory button.



## 9.2 Recall from memory

From the main menu , select memory

The current parameter will be displayed and the option to save



Select yes and then , select the memory location to use (the current contents of that location will be displayed)

Highlight the desired memory location and press to load.



# 10.0 MMA Welding

Follow the screen prompts to complete the machine setup. Example setting.



Adjust Amperage Value



Setting Guide

## 10.1 Advanced MMA welding

Press the advanced button on the front panel



In the advanced manu there are three options



Arc force is an adjustment that allows the amperage to increase as the arc becomes shorter, this in effect increase the ability of the arc to dig into the work piece and so increase penetration and it also prevents the electrode shorting out and sticking if the arc becomes too short



Arc length, control, normally during increasing the arc length causes the voltage to rise and the current fall. The arc length control allows you to compensate for this by boosting the current with a longer arc length



**Hot Start:** This is a temporary increase in the output current during the start of the stick welding process. This helps ignite the arc quickly and reliably

After completing you adjustments you can return to the welding screen using the back button.

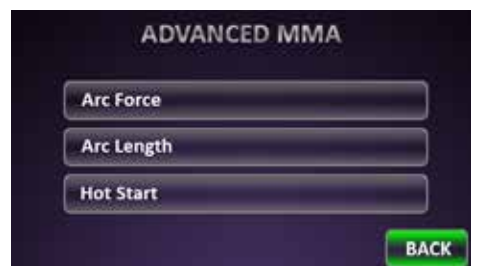

# 11.0 TIG Welding Guide

## 11.1 Advanced MMA welding

### Torch starting in Lift TIG mode

Ensure the gas supply is switched on to the machine. Briefly contact the tip of the tungsten electrode down onto the work piece with the torch at around 70° from vertical. Depress the trigger to start the gas flow and switch on the power, lift the torch up from the work piece to draw out an arc. To prevent melting of the end of the tungsten the machine will increase the output current when it detects the rise in arc voltage as the tungsten is lifted from the work piece. At the end of the weld release the torch trigger and the power

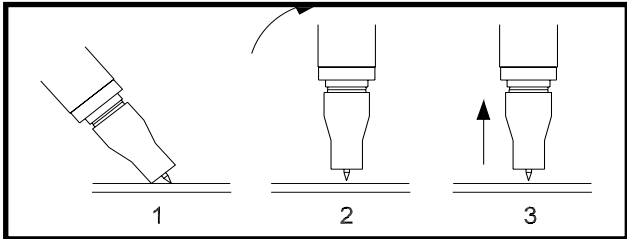

will slope down and switch off.

### Torch starting in HF mode

Ensure the gas supply is switched on to the machine. Hold the torch with the tip of the tungsten approx 2-3 mm from the job. Depress the trigger to start the gas flow and switch on the power. At the end of the weld release the torch trigger and the power will slope down and switch off.

### TIG welding guide ranges

Electrode diameter	AC current (amps)	DC current (amps)
0.040" (1.0mm)	15-30	20-60
1/16" (1.6mm)	60-120	75-150
3/32" (2.4mm)	100-180	150-250

### Tungsten electrode types

Type	Application	Colour
Thoriated 2%	DC welding of mild steel, Stainless steel and Copper	Red

Type	Application	Colour
Ceriated 2%	DC welding of mild steel, Stainless steel, Copper AC welding of aluminium, magnesium and their alloys	Grey
Zirconiated	AC welding of aluminium, magnesium and their alloys	White

### Guide for selecting filler wire diameter

Filler wire diameter	Current range
1/16" (1.6 mm)	20 - 90
3/32" (2.4 mm)	65 - 115
1/8" (3.2 mm)	100 - 165
3/16" (4.8 mm)	200-350

The filler wire diameter specified is a guide only, other diameter wires may be used according to the welding application.

### Shielding gas selection

Alloy	Shielding gas
Aluminium & alloys	Pure Argon
Carbon steel	Pure Argon
Stainless steel	Pure Argon

Nickel alloy	Pure Argon
Copper	Pure Argon
Titanium	Pure Argon

## 11.2 MMA Welding Guide

### Effects of MMA welding various materials

#### High tensile and alloy steels

The two most prominent effects of welding these steels are the formation of a hardened zone in the weld area, and, if suitable precautions are not taken, the occurrence in this zone of under-bead cracks. Hardened zone and under-bead cracks in the weld area may be reduced by using the correct electrodes, preheating, using higher current settings, using larger electrodes sizes, short runs for larger electrode deposits or tempering in a furnace.

#### Manganese steels

The effect on manganese steel of slow cooling from high temperatures is embrittlement. For this reason it is absolutely essential to keep manganese steel cool during welding by quenching after each weld or skip welding to distribute the heat.

#### Cast iron

Most types of cast iron, except white iron, are weldable. White iron, because of its extreme brittleness, generally cracks when attempts are made to weld it. Trouble may also be experienced when welding white-heart malleable, due to the porosity caused by gas held in this type of iron.

#### Copper and alloys

The most important factor is the high rate of heat conductivity of copper, making preheating of heavy sections necessary to give proper fusion of weld and base metal.

#### Types of electrodes

Arc welding electrodes are classified into a number of groups depending on their applications. There are a great number of electrodes used for specialized industrial purposes which are not of particular interest for everyday general work. These include some low hydrogen types for high tensile steel, cellulose types for welding large diameter pipes, etc. The range of electrodes dealt with in this

publication will cover the vast majority of applications likely to be encountered; are all easy to use and all will work on even the most basic of welding machines.

Metals being joined & electrode comments

Mild steel

6013 ideal electrodes for all general purpose work. Features include outstanding operator appeal, easy arc starting and low spatter.

Cast iron

99% nickel suitable for joining all cast irons except white cast iron

Stainless steel

318L-16 high corrosion resistance. Ideal for dairy work, etc. On stainless steels.

## 12.0 Fault Finding



- If error message is displayed allow machine to cool with power off for 10 minutes.
- If error remains switch off and on again.
- Reduce welding current to prevent over current condition.
- If error remains contact your local service centre.

### 12.1 MMA Welding Problems

Description	Possible cause	Remedy
Gas pockets or voids in weld metal (porosity)	(a) Electrodes are damp (b) Welding current is too high. (c) Surface impurities such as oil, grease, paint, etc	(a) Dry electrodes before use (b) Reduce welding current (c) Clean joint before welding
Crack occurring in weld metal soon after solidification.	(a) Rigidity of joint. (b) Insufficient throat thickness. (c) Cooling rate is too high.	(a) Redesign to relieve weld joint of severe stresses or use crack resistance electrodes. (b) Travel slightly slower to allow greater build up in throat. (c) Preheat plate and cool slowly.

## 11.2 TIG Welding Problems

Weld quality is dependent on the selection of the correct consumable, maintenance of equipment and proper welding technique.

Description	Possible cause	Remedy
A gap is left by failure of the weld metal to fill the root of the weld	(a) Welding current is too low. (b) Electrode too large for joint. (c) Insufficient gap (d) Incorrect sequence	(a) Increase welding current (b) Use smaller diameter electrode. (c) Allow wider gap (d) Use correct build-up sequence
Portions of the weld run do not fuse to the surface of the metal or edge of the joint.	(a) Small electrodes used on heavy cold plate (b) Welding current is too low (c) Wrong electrode angle (d) Travel speed of electrode is too high (e) Scale or dirt on joint surface	(a) Use larger electrodes and preheat the plate (b) Increase welding current (c) Adjust angle so the welding arc is directed more into the base metal (d) Reduce travel speed of electrode (e) Clean surface before welding.

Description	Possible cause	Remedy
Non-metallic particles are trapped in the weld metal (slag inclusion).	(a) Non-metallic particles may be trapped in undercut from previous run (b) Joint preparation too restricted (c) Irregular deposits allow slag to be trapped. (d) Lack of penetration with slag trapped beneath weld bead. (e) Rust or mill scale is preventing full fusion. (f) Wrong electrode for position in which welding is done.	(a) If bad undercut is present, clean slag out and cover with a run from a smaller diameter electrode. (b) Allow for adequate penetration and room for cleaning out the slag (c) If very bad, chip or grind out Irregularities (d) Use smaller electrode with sufficient current to give adequate penetration. (e) Use suitable tools to remove all slag from corners (f) Use electrodes designed for position in which welding is done, otherwise proper control of slag is difficult.

Description	Possible cause	Remedy
Excessive bead build up or poor penetration or poor fusion at edges of weld	Welding current is too low	Increase weld current and/or faulty joint preparation
Weld bead too wide and flat or undercut at edges of weld or excessive burn through	Welding current is too high	Decrease weld current
Weld bead too small or insufficient penetration or ripples in bead are widely spaced apart	Travel speed too fast	Reduce travel speed
Weld bead too wide or excessive bead build up or excessive penetration in butt joint	Travel speed too slow	Increase travel speed
Uneven leg length in fillet joint	Wrong placement of filler rod	Re-position filler rod
Electrode melts when arc is struck	Electrode is connected to the '+' terminal	Connect the electrode to the '-' terminal
Dirty weld pool	(a) Electrode contaminated through contact with work piece or filler rod material (b) Gas contaminated with air	(a) Clean the electrode by grinding off the contaminates (b) Check gas lines for cuts and loose fitting or change gas cylinder

Description	Possible cause	Remedy
Electrode melts or oxidizes when an arc is struck	(a) No gas flowing to welding region (b) Torch is clogged with dust (c) Gas hose is cut (d) Gas passage contains impurities (e) Gas regulator is turned off (f) Torch valve is turned off (g) The electrode is too small for the welding current	(a) Check the gas lines for kinks or breaks and gas cylinder contents (b) Clean torch (c) Replace gas hose (d) Disconnect gas hose from torch then raise gas pressure to blow out impurities. (e) Turn on (f) Turn on (g) Increase electrode diameter or reduce the welding current
Poor weld finish	Inadequate shielding gas	Increase gas flow or check gas line for gas flow problems

Description	Possible cause	Remedy
Arc flutters during TIG welding	(a) Tungsten electrode is too large for the welding current (b) Absence of oxides in the Weld pool.	(a) Select the right size electrode. Refer to basic TIG welding guide. (b) Refer basic TIG welding guide for ways to reduce arc flutter
Welding arc cannot be established	(a) Work clamp is not connected to the work piece or the work/torch leads are not connected to the machine (b) Torch lead is disconnected (c) Gas flow incorrectly set, cylinder empty or the torch valve is off	a) Connect the work clamp to the work piece or connect the work/torch leads to the right welding terminals. (b) Connect it to the '-' terminal. (c) Select the right flow rate, change cylinders or turn torch valve on.
Arc start is not smooth	(a) Tungsten electrode is too large for the welding current . (b) The wrong electrode is being used for the welding job. (c) Gas flow rate is too high. (d) Incorrect shielding gas is being used. (e) Poor work clamp connection to work piece	(a) Select the right size electrode (b) Select the right electrode type. Refer to basic TIG welding guide (c) Select the correct rate for the welding job. Refer to basic TIG welding guide (d) Select the right shielding gas. Refer to basic TIG welding guide (e) Improve connection to work piece

## 13.0 Accessories

### 13.1 Torch Spares

Stock Code	Description
CKE403	Electrode Holder with 3m Lead
CKC403	Earth Lead 3m with Clamp
IV8-12S3D218	Pro TIG Torch with 3 button switch
WP26AK	TIG Spares Kit in Plastic Case

### 13.2 Gas Equipment

#### Everyday Gas Regulators – 300 BAR Single Stage

##### Features

Flow rate up to 96m<sup>3</sup>/h (3389 ft<sup>3</sup>/h)

- Full 300 bar capability
- Outlet pressure indicated on the bonnet
- Bottom entry design suited for top outlet cylinder valves



##### Fittings

- Fitted with standard 3/8" BSP outlet
- Fitted with 5/8" BSP inlet connections

Stock Code	Description	Maximum Outlet Pressure
E700140	Argon Preset Regulator	3.0 Bar
E700141	Argon Indicator Regulator	3.0 Bar
E700113	1 Gauge Argon	30 lpm flow
E700123	2 Gauge Argon	30 lpm flow

#### Flow Meters

##### Features

- Designed from brass bar whilst the tube and cover are moulded from high quality polycarbonate to ensure high impact resistance and clarity
- Calibrated to operate at an inlet pressure of 30PSI
- Sensitive needle valve provides easy adjustment and the downward facing outlet connection eliminates hose kinking.



##### Fittings

- Fitted with standard 3/8" BSP inlet and outlet connections

Stock Code	Description
706100	Flow Meter Mixed Gas 15 lpm

13.3 TIG Torch Schematic

# PRO18 and PRO18FX

## Water Cooled Pro-Grip® TIG Welding Torch

Rating: 350A DC, 260A AC @ 100% Duty Cycle, EN60974-7 .020" to 5/32"2/0.5mm-4.0mm Electrodes

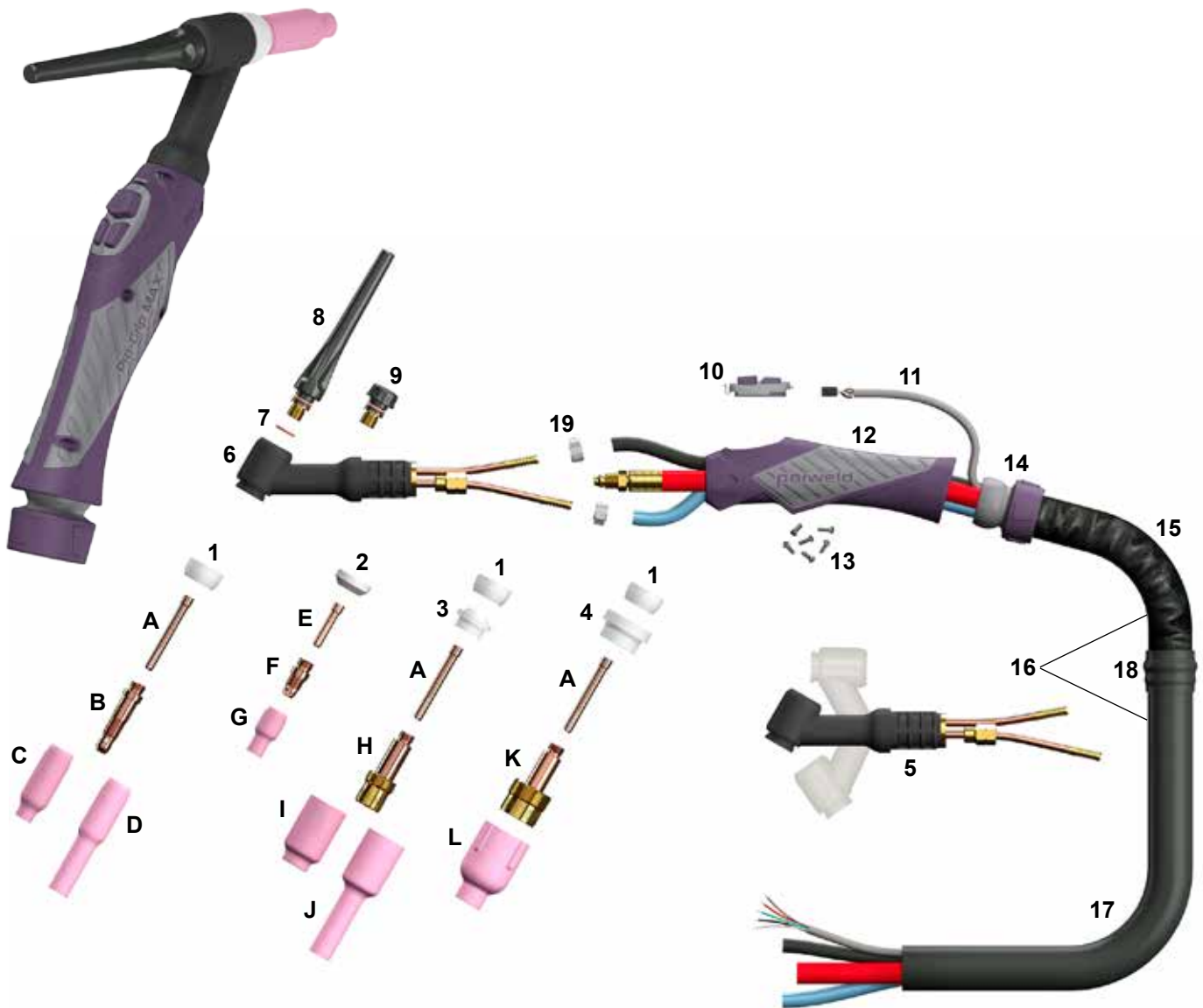

Standard Collet		
Stock Code	Description	
A 10N21	Standard Collet .020"/0.5mm Bore	
10N22	Standard Collet .040"/1.0mm Bore	
10N23	Standard Collet 1/16"/1.6mm Bore	
10N23M	Standard Collet 5/64"/2.0mm Bore	
10N24	Standard Collet 3/32"/2.4mm Bore	
10N25	Standard Collet 1/8"/3.2mm Bore	
54N20	Standard Collet 5/32"/4.0mm Bore	

Standard Collet Body		
Stock Code	Description	
B 10N29	Standard Collet Body .020"/0.5mm Bore	
10N30	Standard Collet Body .040"/1.0mm Bore	
10N31	Standard Collet Body 1/16"/1.6mm Bore	
10N31M	Standard Collet Body 5/64"/2.0mm Bore	
10N32	Standard Collet Body 3/32"/2.4mm Bore	
10N28	Standard Collet Body 1/8"/3.2mm Bore	
406488	Standard Collet Body 5/32"/4.0mm Bore	

Standard Ceramic Cup		
Stock Code	Description	
C 10N50	Standard Ceramic Cup 1/4"/6mm Bore	
10N49	Standard Ceramic Cup 5/16"/8mm Bore	
10N48	Standard Ceramic Cup 3/8"/10mm Bore	
10N47	Standard Ceramic Cup 7/16"/11mm Bore	
10N46	Standard Ceramic Cup 1/2"/13mm Bore	
10N45	Standard Ceramic Cup 5/8"/16mm Bore	
10N44	Standard Ceramic Cup 3/4"/19mm Bore	

Standard Long Ceramic Cup		
Stock Code	Description	
D 10N49L	Long Ceramic Cup 5/16"/8mm Bore	
10N48L	Long Ceramic Cup 3/8"/10mm Bore	
10N47L	Long Ceramic Cup 7/16"/11mm Bore	

Stubby Series Collet		
Stock Code	Description	
E 10N21S	Stubby Collet .020"/0.5mm Bore	
10N22S	Stubby Collet .040"/1.0mm Bore	
10N23S	Stubby Collet 1/16"/1.6mm Bore	
10N24S	Stubby Collet 3/32"/2.4mm Bore	
10N25S	Stubby Collet 1/8"/3.2mm Bore	

Stubby Collet Body		
Stock Code	Description	
F 17CB20	Stubby Collet Body .020"-1/8"/0.5mm-3.2mm Bore	

Stubby Standard Ceramic Cup		
Stock Code	Description	
G 13N08	Standard Ceramic Cup 1/4"/6mm Bore	
13N09	Standard Ceramic Cup 5/16"/8mm Bore	
13N10	Standard Ceramic Cup 3/8"/10mm Bore	
13N11	Standard Ceramic Cup 7/16"/11mm Bore	
13N12	Standard Ceramic Cup 1/2"/13mm Bore	
13N13	Standard Ceramic Cup 5/8"/16mm Bore	

Gas Lens Body		
Stock Code	Description	
H 45V24	Gas Lens Body .040"/1.0mm Bore	
45V25	Gas Lens Body 1/16"/1.6mm Bore	

Gas Lens Body - continued		
Stock Code	Description	
45V26	Gas Lens Body 3/32"/2.4mm Bore	
45V27	Gas Lens Body 1/8"/3.2mm Bore	
45V28	Gas Lens Body 5/32"/4.0mm Bore	

Standard Gas Lens Cup		
Stock Code	Description	
I 54N18	Standard Gas Lens Cup 1/4"/6mm Bore	
54N17	Standard Gas Lens Cup 5/16"/8mm Bore	
54N16	Standard Gas Lens Cup 3/8"/10mm Bore	
54N15	Standard Gas Lens Cup 7/16"/11mm Bore	
54N14	Standard Gas Lens Cup 1/2"/13mm Bore	
54N19	Standard Gas Lens Cup 11/16"/17mm Bore	

Long Gas Lens Cup		
Stock Code	Description	
J 54N17L	Long Gas Lens Cup 5/16"/8mm Bore	
54N16L	Long Gas Lens Cup 3/8"/10mm Bore	
54N15L	Long Gas Lens Cup 7/16"/11mm Bore	

Large Diameter Gas Lens Body		
Stock Code	Description	
K 45V116	Large Dia Gas Lens Body 1/16"/1.6mm Bore	
45V64	Large Dia Gas Lens Body 3/32"/2.4mm Bore	
995795	Large Dia Gas Lens Body 1/8"/3.2mm Bore	

Large Diameter Gas Lens Cup		
Stock Code	Description	
L 57N75	Large Diameter Gas Lens Cup 3/8"/10mm Bore	
57N74	Large Diameter Gas Lens Cup 1/2"/15mm Bore	
53N88	Large Diameter Gas Lens Cup 5/8"/16mm Bore	
53N87	Large Diameter Gas Lens Cup 3/4"/19mm Bore	

Components		
Stock Code	Description	
1 18CG	Cup Gasket	
2 18CG20	Cup Gasket for Stubby Collet Body	
3 54N01	Gas Lens Insulator (use with 18CG)	
4 54N63	Insulator Large Diameter Gas Lens (use with 18CG)	
5 PRO18FX	Torch Head Flexible	
6 PRO18	Torch Head including Cup Gasket	
7 98W18	Back Cap O Ring	
8 PRO57Y02	Back Cap Long	
9 PRO57Y04	Back Cap Short	
10 PRO3MS	3 Button Momentary Switch Kit	
11 PROSWL4	Connector + Leads x 4mt/13.2ft	
PROSWL8	Connector + Leads x 8mt/26.2ft	
12 PROH200	Pro-Grip® Tig Handle Large	
13 PROSP	Screw Pack	
14 PROKJ200	Knuckle Joint c/w Lock Nut	
15 PROLC200-08	Leather Cover x 0.8mt/2.6ft	
16 PROCO200-40	Complete Cover Assembly x 4mt/13.2ft	
PROCO200-80	Complete Cover Assembly x 8mt/26.2ft	
17 PRONCL-32	Neoprene Cover x 3.2mt/10.5ft	
PRONCL-72	Neoprene Cover x 7.2mt/23.6ft	
18 PROJK200	Sheath Jointing Repair Kit	
19 B5024	Hose Clamp 9.5mm	

## 14.0 EC Declaration of Conformity

Hereby we declare that the machines as stated below

Type: XTT 315Di

Conform to the EC Directives:

Low Voltage Directive 2014/35/EEC

EMC Directive 2014/35/EEC

Harmonised European standard: EN/IEC 60974-1

This is to certify that the tested sample is in conformity with all provisions of the above detailed EU directives and product standards.



## 14.1 RoHS Compliance Declaration

Directive 2011/65/EU of the European Parliament

Amended 2015/863 and 2017/2102

Restriction of use of certain hazardous substances in electrical and electronic equipment

Type: XTT 315Di

The above listed products are certified to be compliant with the rohs directive with all homogeneous component parts being controlled to ensure material contents as per the list below.

Cadmium 0.01% by weight

Lead 0.1% by weight

Mercury 0.1% by weight

Hexavalent chromium 0.1% by weight

Polybrominated biphenyl's (pbbs) 0.1% by weight

Polybrominated diphenyl ethers (pbdes) 0.1% by weight

It should be noted that under specific exempted applications, where lead is used as an alloying element the following limits are applied in accordance with the regulations.

Copper and copper alloy parts use less than 4% by weight of each homogeneous component.

Steel and steel alloy parts use less than 4% by weight of each homogeneous component.

Aluminium and aluminium alloy parts use less than 4% by weight of each homogeneous component.

Only dispose off in authorised sites for electrical and electronic waste do not dispose of with general refuse or landfill waste.



## 14.2 WEEE Statement

WEEE (Waste Electrical & Electronic Equipment) 2012/19/EU

In relation to implementing the legislation, Parweld has established relevant recycling and recovery methods. We have been fully compliant against the marking requirements since August 2005. Parweld is registered in the UK with the Environment agency as detailed below. For WEE compliance outside the UK please contact your supplier/Importer

Parweld is registered with a compliance scheme Official registration number is WEE/FD0255QV

When your equipment reaches the end of its service life you should return it to Parweld where it will be reconditioned or processed for recycling.

## 14.3 Statement of Warranty

Limited Warranty:

Parweld Ltd, hereafter, "Parweld" warrants its customers that its products will be free of defects in workmanship or material. Should any failure to conform to this warranty appear within the time period applicable to the Parweld products as stated below, Parweld shall, upon notification thereof and substantiation that the product has been stored, installed, operated, and maintained in accordance with Parweld's specifications, instructions, recommendations and recognized standard industry practice, and not subject to misuse, repair, neglect, alteration, or accident, correct such defects by suitable repair or replacement, at Parweld's sole option, of any components or parts of the product determined by Parweld to be defective.

Parweld makes no other warranty, express or implied. This warranty is exclusive and in lieu of all others, including, but not limited to any warranty of merchantability or fitness for any particular purpose.

Limitation of Liability:

Parweld shall not under any circumstances be liable for special, indirect or consequential damages, such as, but not limited to, lost profits and business interruption. The remedies of the purchaser set forth herein are exclusive and the liability of Parweld with respect to any contract, or anything done in connection therewith such as the performance or breach thereof, or from the manufacture, sale, delivery, resale, or use of any goods covered by or furnished by Parweld whether arising out of contract, negligence, strict tort, or under any warranty, or otherwise, shall not, except as expressly provided herein, exceed the price of the goods upon which such liability is based. No employee, agent, or representative of Parweld is authorized to change this warranty in any way or grant any other warranty.

Purchaser's rights under this warranty are void if replacement parts or accessories are used which in Parweld's sole judgement may impair the safety or performance of any Parweld product.

Purchaser's rights under this warranty are void if the product is sold to purchaser by non-authorized persons.

The warranty is effective for the time stated below beginning on the date that the authorized Distributor delivers the products to the purchaser. Notwithstanding the foregoing, in no event shall the warranty period extend more than the time stated plus one year from the date Parweld delivered the product to the authorized distributor.

---

Parweld Limited  
Bewdley Business Park  
Long Bank  
Bewdley  
Worcestershire  
England  
DY12 2TZ

tel. +44 1299 266800

[www.parweld.com](http://www.parweld.com)  
[info@parweld.co.uk](mailto:info@parweld.co.uk)