



Parweld Limited
Bewdley Business Park
Long Bank
Bewdley
Worcestershire
England
DY12 2TZ
Tel: +44 1299 266800
www.parweld.com
info@parweld.co.uk

WF405 Wire Feed Unit

ASSEMBLY INSTRUCTIONS

Parts List

- 1) Wire Feed Unit
- 2) Wire Feed Unit Location Plate
- 3) Machine Location Plate
- 4) Screws for Machine Location Plate
- 5) Rubber Strip to line the inside of Clamp item (6)
- 6) Clamp for Interconnect Cable Assembly
- NI) Wheel Kit part no. 5310390 (optional extra to replace feet)

Step 1

- 1) Remove 4 screws circled
- 2) Position wire feed unit location plate item (2) so that hole A corresponds to screw A
- 3) Re-assemble the screws

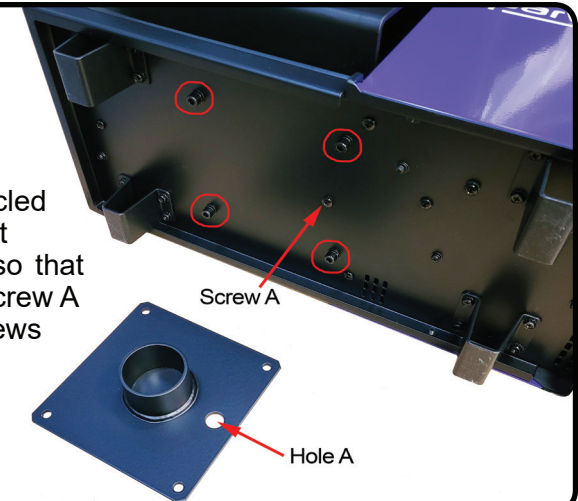

Step 2

- Fasten machine location plate item (3) to handle plate on trolley using screws item (4)



Step 3

- 1) Remove clamp (6)
- 2) Position rubber strip (5) inside clamp (6) to protect cables
- 3) Once the interconnect cable is connected, assemble the clamp complete with rubber strip

