



Parweld PUSH PULL Torch

User Manual

parweld 
WELDING THE FUTURE



Safety



WARNING



Read Instructions

Before using this product, read the instructions and any related data sheets. (See www.parweld.com).



Fumes and Gases

Fumes and gases emitted during welding may be dangerous, use adequate ventilation and extraction equipment.



Arc Rays

Arc rays may burn eyes and skin. Wear protective clothing.



Electric Shock

Electric shocks can kill, use adequate protective equipment. Ensure a safe earth connection. Do not touch electrical parts or electrode.



Burn and Fire Hazard

Weld and metal parts are hot and cause serious burn injuries if touched. Sparks can cause burns and fire. Remove all flammable materials from the welding area.



Injury can occur from bodily contact with hot parts, sparks, fumes, dust, noise and vibration.



Protect your eyes and face with a mask fitted with a filter lens. Use welding screens.



Wear protective clothing to protect your body and ears.



Use adequate ventilation or wear respirator equipment to prevent dust, fumes and gases from entering your lungs.

Parweld Push Pull Torch Introduction

Function

The Parweld Push Pull MIG welding torch consists of a mechanical drive block that incorporates a DC drive motor. This drives feed rolls that pull the welding wire push fed from a wire feeding unit and power source, feeding it through a MIG welding swan neck front end.

Swan Neck

The welding torch is supplied with a neck fitted. This normally would be an XP8 range model, 350A air cooled or 450A water cooled. Other ranges and models are available to suit customer preferences for front end consumables. All necks are fully rotatable through 360° and are available in a range of neck lengths and angles. See separate rotating neck data sheets for more details on availability. (See www.parweld.com).

Wire Feed Speed Control

Different welding wire feed rates can be selected via a speed control mounted on a separate drive module. The drive module is fitted to the power source and connected to the torch control input lead. For more details on the drive module see the PP0117 Users Manual. (See www.parweld.com).

An optional remote control is also available as a torch handle mounted control which allows instantaneous wire feed speed adjustment.

Torch Length

Torches are available in three lengths, 6, 8 and 10m.

Technical Data

Welding Torch	XP8 350A	XP8 450W
At 80% Duty Cycle Mixed Gas (80/20)	10.5KW	15.8KW
Wires	0.8 - 1.6mm	

Reference Torch Wire Feed Data

Nominal Wire Feed Speed	M/Min	Ft/Min	
Min	1.5	4.9	+/- 10%
Max	28.5	93.5	+/- 10%

Torch Maintenance



Neck Fitting

Disconnect the torch from the power supply so that it can not be triggered accidentally.

- At the neck root slacken the nut which secures the neck to the torch mount.
- The mount tapered design creates a strong fit. To remove the neck twist to release it.
- The neck liner and nipple combination will also need to be removed.
- The new neck will have a new neck liner and choice of nipples supplied, select the nipple for the push pull torch.
- Fit the neck liner and nipple into the neck. trim the liner material if necessary to correct the length as detailed below.
- Fit both the neck and neck liner into the torch neck mount.
- Tighten the neck nut. If a swan neck, before fully tightened position the neck in the orientation required. Then fully tighten the nut to secure.

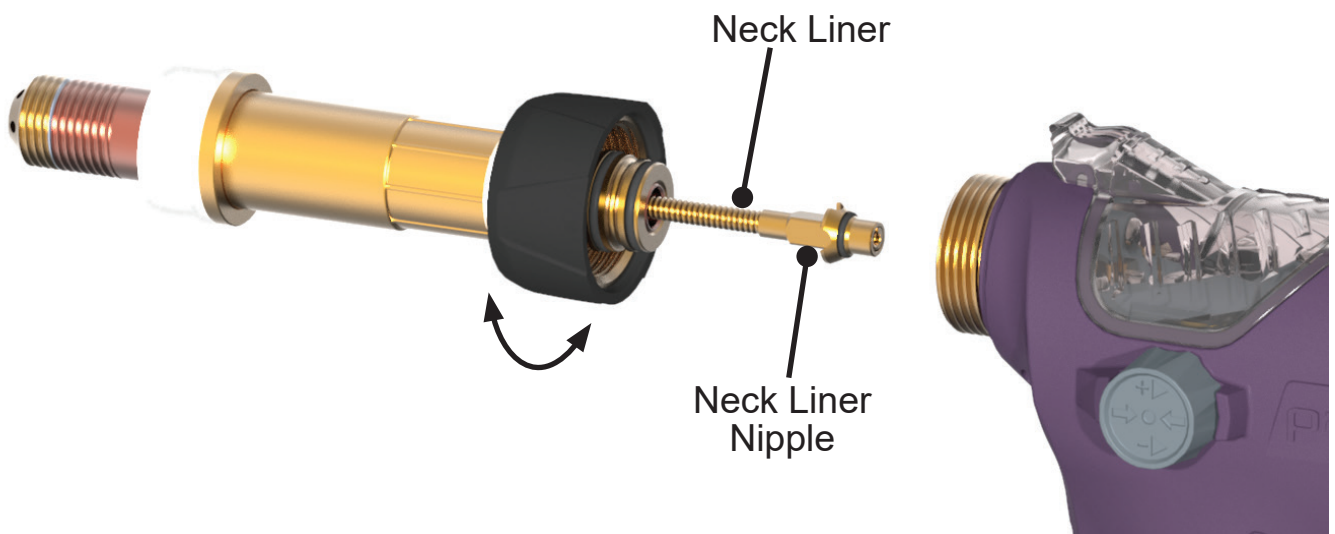



Nozzle and Front End Consumables

Remove the nozzle from the front of the neck. Remove all spatter from the head, gas diffuser and the nozzle. These components must be clean and free of all debris to ensure efficient gas flow and to prevent short circuit. Check all front end consumables for damage and wear. Replace with new if necessary.



To maintain the best performance repeatedly check and clean the front end consumables periodically. Also use a Parweld anti spatter spray on the consumables to reduce the build up of debris.

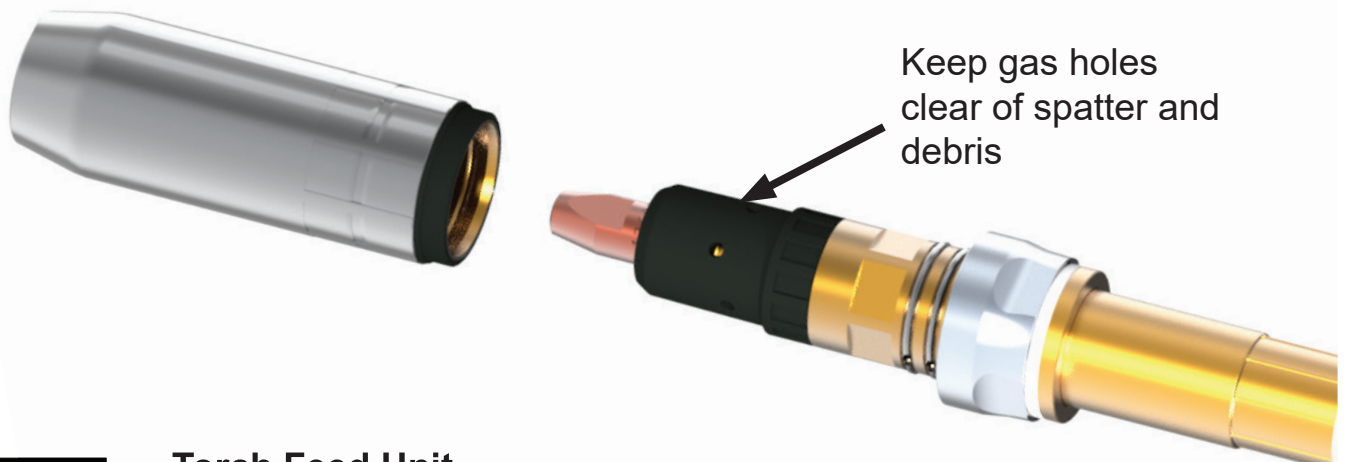

Torch Feed Unit

Open the torch feed unit hatch and inspect. Wire scale debris will build up inside the torch around the feed unit mechanism. Regularly clean out the torch feed unit using an air blow gun to blow out this debris.

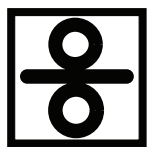

To maintain the best operation of the torches feed mechanism clean out the debris daily before use at the very least.

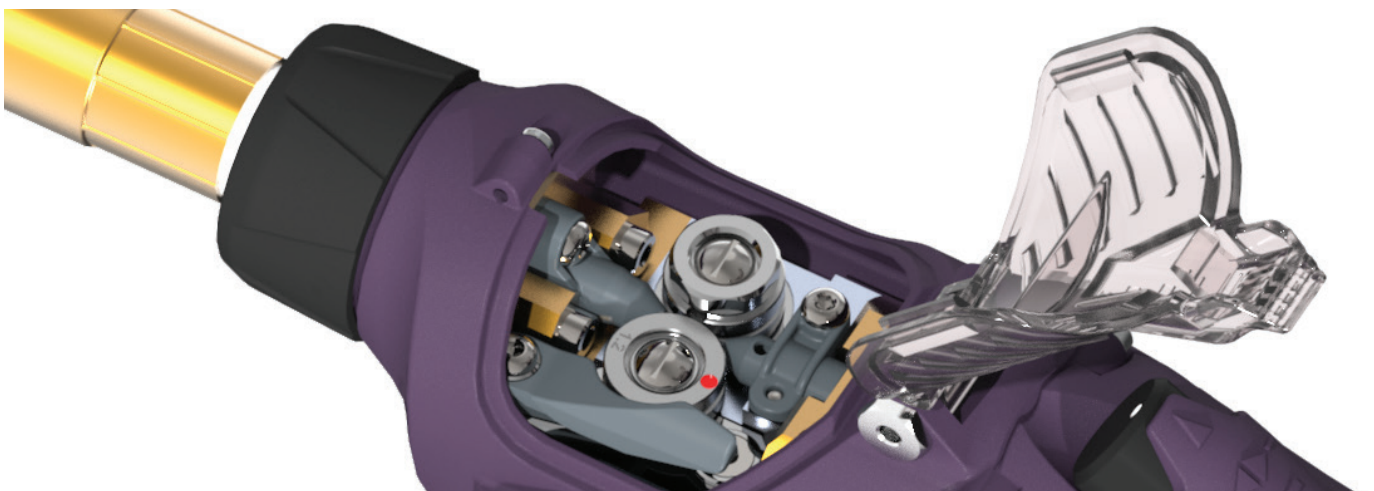



Feed Rolls

The feed rolls will wear over time. Check the roll grooves for wear and debris. Debris can be removed with a wire brush. If the groove is excessively worn, replace.

To change the feed rolls;

- Use a flat blade screw driver to slacken off and remove the retaining screws for both the pressure roll and the feed roll.
- The drive roll has a retaining cap to lock the roll to the drive shaft. This will lift off.
- The rolls can then be retracted off their shaft mounts. Use the flat blade screw driver to lever them if they are tight.
- Replace the rolls with the required size.
- The pressure roll has an internal bearing fitted and will only fit the pressure arm shaft mount.
- The drive roll is slotted and must be fitted to the drive shaft with the slot aligned with the shaft slot. Then the retaining cap fitted on top.
- Secure both rolls with the screws, tightening with a screw driver.

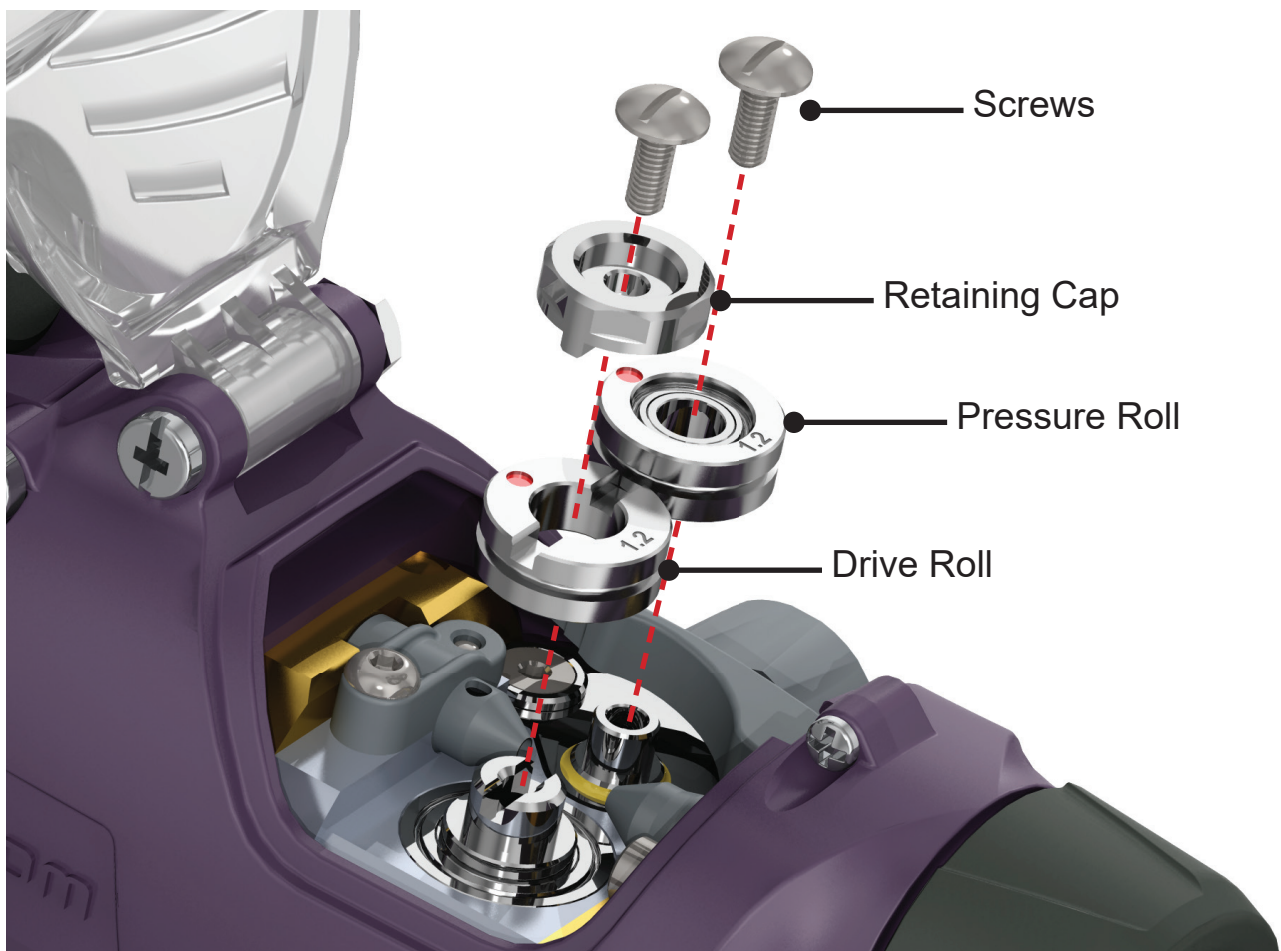



Neck Wire Inlet Guide

The neck guide will wear as the wire is fed through into the neck. To maintain trouble free wire feeding periodically check and renew this guide.

To remove the guide;

- Remove the retaining screw using a hexagonal key. 2mm A/F.
- Lift the guide out of its location. Removing the feed rolls will make this easier.
- There is a renewable liner inner that can be replaced. Remove the gas seal O ring and then withdraw the guide liner.
- Replace the liner inner with new and fit an O ring.
- Return the guide assembly into the drive unit location ensuring the O ring and liner tube locate correctly. Secure using the retaining screw.

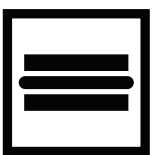
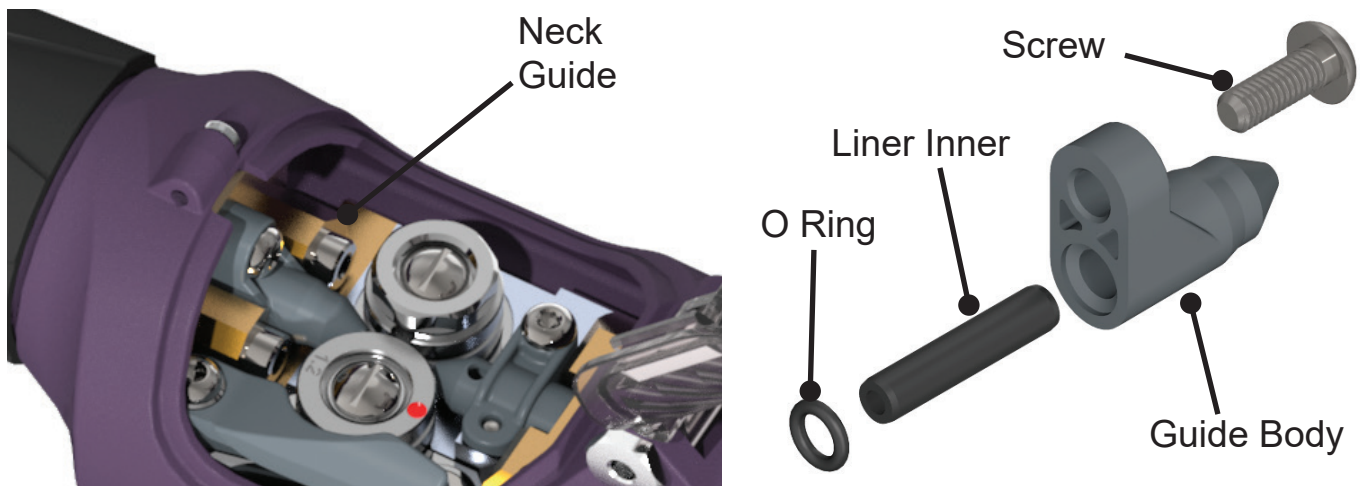

Liner Fitting

To fit a new liner;

- Lay the torch out straight on a flat surface.
- Remove the liner retaining nut from the gun plug body liner stem.
- Remove the old liner by pulling it out of the stem.
- Feed the new liner into the gun plug liner stem. Push up the torch until it hits the guide in the torch handle. The liner should be visible through the inspection hole of the guide.
- Now position the liner nipple and O ring in the liner stem, fit and tighten the retaining nut over the nipple.
- Trim the excess liner length to suit the machine feed unit configuration into which the torch will be fitted.

Torch Installation

Connecting To Feed Unit Power Source

- Push the torch gun plug body into the machine connection socket, feeding the liner into the socket through to the wire feeder feed rolls.
- Screw the gun plug nut onto the socket until fully tighten.
- Connect water in/return hoses if using a water cooled torch.

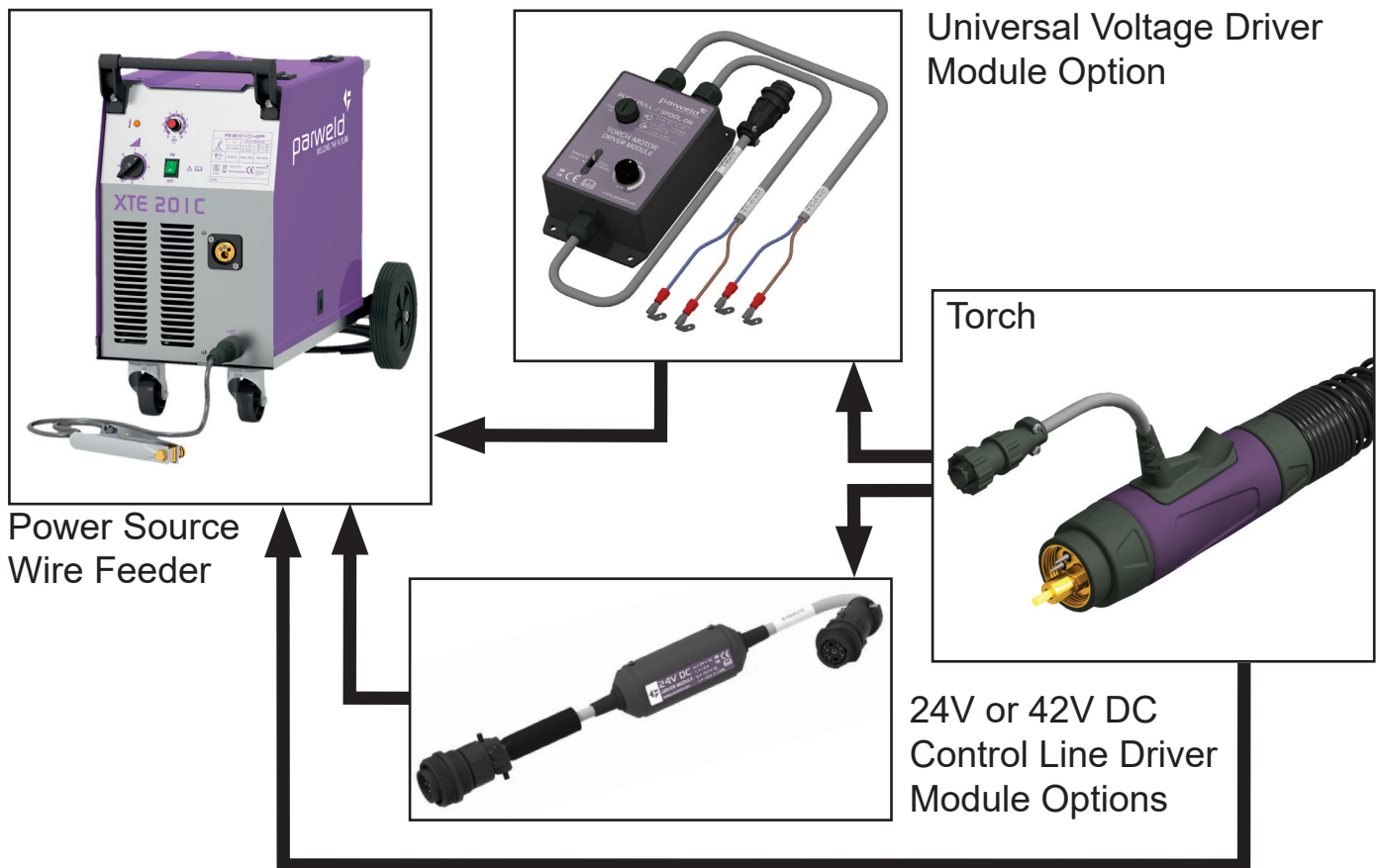

Connecting Driver Control Module

If using the Parweld Universal voltage drive module PP0117, follow the connection procedure as detailed in the separate drive module user manual (See www.parweld.com), connecting the torch control lead to the Parweld Drive module connector and the module into the machines power and switching circuits.

If using 24V or 42V DC control line driver modules, PP0126-24 or PP0126-42, connect the module to the torch then the other end to the machine control socket.

Torch Set Up



Roll Pressure

Before changing the feed rolls or feeding the wire through the torch the pressure on the pressure roll must be reduced.



- First check to see if there is any pressure on the pressure roll by opening the feed unit hatch and pulling on the release arm. If there is pressure on the roll the lever will be stiff and will not make the pressure roll move.
- To slacken off the pressure, turn the pressure adjustment knob on the side of the torch anti-clockwise. Turn two or three times and check the pressure release lever again. If the feed roll moves away from the drive roll easily then enough pressure has been taken off.

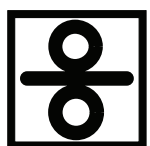
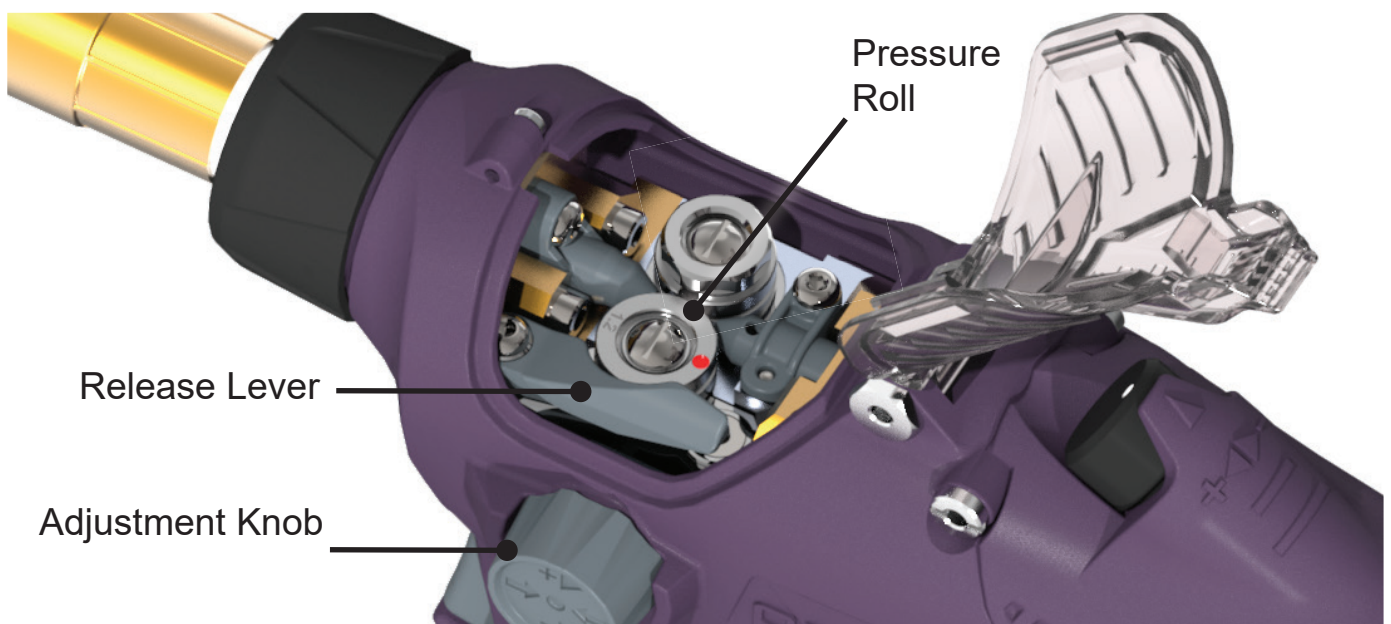

Feed Roll Selection

Open the feed unit hatch to check the correct feed rolls are fitted for the wire to be fed.

There are two groove types, one for soft wires and one for hard wires. Check which groove type you need. The rolls are marked on the top face with a wire size as two digits. For soft wires there is also a letter "A" marked. For quick reference there is also a colour mark relating to the wire size. For further information see the push pull feed roll data sheet. (See www.parweld.com).

To change them follow the procedure as described in the maintenance section.

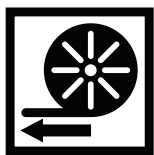

Feeding Wire

For best feeding results lay the torch flat and straight on the ground. Setup the wire in the power source feed unit ready to be fed through the torch. If the wire has a strong cast, feeding can be improved by adding a slight bend in the end of the wire to straighten it, before clamping in the feed rolls.

To feed the wire through the torch;

- Turn on the power source.
- Press the torch trigger. This should start the power source feed unit drive and the torch feed unit drive simultaneously.
- The wire will feed up through the torch. Use the speed control of the power source wire feed unit to vary the wire feed speed, slowing the wire as it reaches the end of the torch.
- As the wire feeds into the torch feed unit have the rolls in the open position by pulling on the roll pressure release lever, which should be adjusted to a low pressure load.
- When the wire passes between the rolls release the trigger to stop the drive.
- Release the lever to close the rolls together. You may need to push the wire between the rolls, into the roll grooves, using a flat blade screw driver.
- Operate the torch trigger again to feed the wire into the neck guide and through the neck.
- When the wire is visible from the end of the contact tip release the trigger to stop the wire feeding.

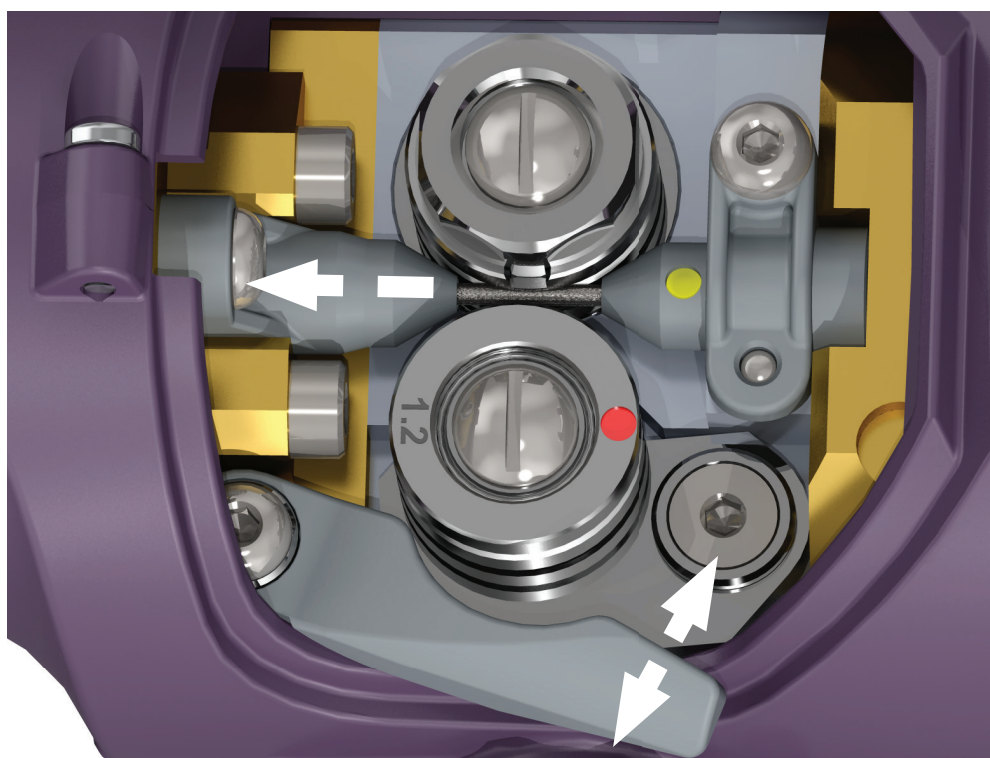



Roll Pressure Adjustment

Before welding the pressure roll will need to be tightened against the wire sat in the groove of the two feed rolls.

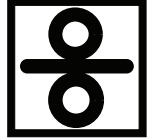

To adjust;

- Turn the pressure adjustment knob on the side of the torch in the clockwise direction. Turn one, two or three times to load up the pressure on the rolls.
- If during welding the rolls appear to be loosing grip on the wire, add more pressure to the rolls by additional clockwise turns on the adjustment knob.

Do not over tighten as this may damage the wire and cause excessive debris build up in the drive unit.

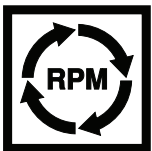

Drive Speed Adjustment

For the best feeding results the torch drive should be set up so that the rolls rotate slightly faster than the wire feed speed from power source feed unit.



Adjust the drive speed using the speed control on the drive module or remote control on the torch if fitted.



Control
Module
Speed
Control



Remote Speed
Control

Set too slow the wire may back up behind the roll and cause a jam if it “birds nests”.

Set too fast the wire may be damaged by the feed rolls skidding on the wire. Causing excessive amounts of debris collecting in the drive unit of the torch. Also the Rolls with wear excessively causing erratic feeding.

Before welding press the torch trigger and visually check the drive is working and how the wire passes through the torch. Once happy with the set up, close the hatch, trim the excess wire, the torch is ready to weld.

Trouble Shooting

Problem	Remedy
Wire feeder does not activate when torch trigger is operated	Check and secure torch gun plug connection with the feeding machine
	Check torch trigger is operating and connection is made through the torch
	Check feeding machine via the users manual
Wire feeder activates when torch trigger is operated but torch drive does not feed	Check and secure the control lead connection with the drive module
	Check the input voltage and drive signal lead connection are made to the correct terminals in the source feeder machine.
	Check the speed control selector switch is in the correct position for the torch configuration connected.
	Adjust the speed control trimmer, either on the drive module or the torch depending on the torch configuration
Torch drive speed running at maximum when the trigger is operated, speed trimmer is not effecting the speed when adjusted	Check the speed control selector switch is in the correct position for the torch configuration connected.
	Torch control lead wires may be connected incorrectly.
Torch drive is not running when the trigger is operated, speed trimmer is not effecting the speed when adjusted	Check the speed control selector switch is in the correct position for the torch configuration connected.
	Torch control lead wires may be connected incorrectly.
Remote speed control trimmer fitted to the torch is not affecting the drive speed when adjusted	Check the connections as secure through the torch and with the control lead to the drive module

Problem	Remedy
Wire “birds nests” in torch feed unit behind the feed rolls	Pull drive speed is too slow. Adjust the speed using the local or remote controls depending on torch set up.
Excessive debris build up in torch drive unit	Pull drive speed is too fast, slipping on the wire and abrading the wire surface. Adjust the pull feed speed using the local or remote speed controls depending on torch set up.
Wire feeding erratic	Roll pressure is too low, adjust the pressure by tightening the adjustment knob on the side of the torch.
	Torch feed rolls may be worn or the wrong feed rolls fitted for the wire. Check the feed roll condition and replace if necessary.
Torch drive roll rotates counter-clockwise, against the direction of wire feeding.	Drive motor power supply is connected in reverse polarity. Open the torch gun plug housing and swap the wire connections for the drive motor. The “Red” and “Black” leads.

parweld 



PARWELD LIMITED

**Bewdley Business Park, Long Bank,
Bewdley, Worcestershire DY12 2TZ**

T +44 1299 266 800 F +44 1299 266 900

UK AND IRELAND SALES 01299 269 500

EXPORT SALES +44 1299 269 507

E info@parweld.co.uk www.parweld.com

PP0128BOOK



5 055365 518191 >

**Parweld Push Pull Torch
User Manual**